

Contingency decisions on strategic planning function in conditions of uncertainty (fuzzy environment) based on fuzzy AHP method

Nader Jahantigh¹

*1*Master of Management, School of Imam Baqir (AS), jahantighnader@yahoo.com

ABSTRACT

Identification of the preparation and writing of the research has been followed by an answer to this question, "making contingency operation (based on the requirements of time and place) on strategic planning in terms of uncertainty would be?" "To meet and assess the impact of these two areas can be variable and several indicators outlined, but the evidence suggests that strategic planning under uncertainty based on futures and predict phenomena possible, probable and preferable and each of the options presented in accordance with indicators The strategic plan that is consistent with the goals, Choices for decision and move towards the desired future comes. The fuzzy analytic hierarchy process is also based on the provided options as compared with the corresponding decision variables are paired against him. Therefore, this research is based on the hypothesis; "We can use the fuzzy analytic hierarchy process, With weights to the criteria defined in terms of strategic planning Uncertainty (fuzzy environment), which originated options strategies is then presented The weight of the line choice, the decision ". Finally, the author has concluded that Contingency decision function based on fuzzy AHP method is based on strategic planning in conditions of uncertainty that may be the future, and preference is likely to face a positive functioning, efficient and can be used in the decision-making process.

Original Article:

Received 8 Sep. 2014

Accepted 18 Nov. 2014

Published 30 Mar. 2015

Keywords:

decision making, planning, strategy, strategic planning, fuzzy

1. Introduction

Accepting the fact that a correct understanding of the situation of uncertainty, with a clear understanding of the necessity Making appropriate decisions in a short timeframe associated, we realized that these conditions are being closed because of the uncertainty of the mental pressure on managers and decision-makers in many importing that this result, can be this their fastness, will be limited by some mind-boggling and-in those circumstances the decision options. Also, because of the short duration of decision-making under uncertainty and surprising face to managers with an unexpected situation, they suggest that this option is chosen such shares are limited. Therefore, to the extent that the decision maker More complete and better able to predict the future In order to develop effective strategies to move, Would you ever have different strategies for coping with problems. Conversely, it is more abrupt and unpredictable, the strategy will allow the detection of pre-task oriented its proximity. This limited time opportunity will be to remedy fueled by multiple decision-maker. Since fuzzy hierarchical analysis tool in strategic and long-term decisions in terms of contingency and uncertainty helps managers in their decision-making process to consider the future, and the future of the different options. In such circumstances, events managers, are considered in the future to be a fundamental change in their surroundings. This can be useful for making strategic and long-term management and enables them to build up before the surprise, affordable and acceptable reaction shown in Potential losses because of their uncertainty and instability may be prevented.

In this study, the independent variable and decision making dependent variable used in strategic planning taking advantage of the method will attempt an explanation function of the independent variable on the dependent variable, relying explain the method of AHP and fuzzy.

So have tried using the method based on the fuzzy analytic hierarchy on contingency decisions, managers and decision-makers should be multiple options during the strategic planning of their choice to engage in conditions of uncertainty, In terms of weight calculations and comparisons are presented and paired with the analysis Hierarchical fuzzy that have been paid, the option or options, have the necessary decision.

As stated Fuzzy AHP based on the options in the future with uncertainty and note that the choice of options related to a decision is therefore believed to be the author, If we define the appropriate benchmark for each option It can be weighted according to the options and choose the best strategy Based on the selection, design and strategic planning for the future hypothesis to be adjusted accordingly; "we can use the fuzzy analytic hierarchy process, the weights to the criteria defined In strategic planning, selectable options for scheduling and weighting, In order to select the appropriate option (strategy appropriate to the circumstances and requirements), the decision-making."

Conceptual framework - theoretical research:

2.1. The conceptual framework

2.1.1. Conditions of uncertainty (fuzzy environment)

"The story, especially those with learning experiences and tips about life, and always have been with us. These stories can help us to know what happened in the past, the time now is happening or will happen in the future, meaning our concept. In this sense, the story of the imagination that an individual, group or community to

practice their knowledge, the understanding gained through the experience and knowledge to the next generation. Background of these stories goes back thousands of years, But since the mid-twentieth century, the use of stories as a tool for planning and Learning within organizations concentrate managers, researchers, planners and futurists was special. "[7]

Due to this long-term strategic planning not only to decide that as a kind of futures, forward and draws Track to achieve its investment, they are useful; but to encourage decision makers to be sensitive to future changes in real are also very useful. We have to accept that higher order of disaster and whatever the unexpected before, the fact when we do not consider them to be on the same basis at the time of decision making under conditions of uncertainty about the nature of the act.

"For several decades, it was thought that the uncertainty of the events caused by accidental means they are and it can be used by probability theory, modeling, and the fuzzy theory is that all the uncertainties caused by the random aspect of the event." [2]

"Uncertainty is the word has several meanings that are not exactly what you know, what is our instrument is questionable. What [vaguely defined or not defined, doubt, uncertainty, and/ or what about that awareness is not accurate. Or what [enclosed, volatility, Unreliable or non-viable and are subject to change [is] If we reflect on the meanings, it seems the two uncertainty is achieved, which are vague and are sealed." [2]

"Ambiguous data, the data are usually not clear about the boundaries of theological concepts like almost, almost, etc., which are marked with (~) mode] are derived.

Theological concepts are enclosed data also means understanding them requires more explanation. For example, theological concepts like good manager, quality Karbala, business leadership, task-oriented and data type are enclosed. "[1]

Therefore, "the concepts and the data that they have different perceptions of decision makers, are fuzzy concepts." [1]

2.1.2. General concepts of decision-making:

2.1.2.1. Decision: The decision is a critical moment, "describes the process by which solutions to a certain problem is choice." (Rezayian, 2011) as "the science of decision-making, choosing a solution of the guidelines or priority packaging solutions are concerned." [1]

The decision to fit the appropriate circumstances are different and uncertain. The managers' knowledge toward the accept uncertainty through the appropriate detector sensitivity during the strategic planning process is defined to predict, be directed against an eventual situation happened, it utilizes proper planning and management, Critical fields emanating from the kill.

Although one of the main characteristics of uncertainty, the unexpected is being Decision makers faced with excitement and anxiety. But under normal circumstances the immense possibilities available to authorities In order to deal with the possible conditions of uncertainty are ready-made and it will not be possible except through the formulation of a strategic plan that is appropriate to favorable outlook towards the realization of the payment.

2.1.2.2. Fuzzy decision making, according to previous content "When the decision-making techniques that are discussed in terms of fuzzy data Decisions, are based on a vague and sealed happen." [1] As Lotfi Zadeh, the founder of fuzzy logic expressed, "The ambiguity of, or arising from natural and human perception, or due to the uncertainty in the law as the basis of human judgment is that he is based mainly on past experience. [1]

2.1.3. Analytical Hierarchy:

"Overall, the collection of components or Elements that disrupt the interaction. For example, the economy is dependent on scarce energy resources, Access to energy, the geographical location of the country and its policy is dependent on the ability of the military and political situation it depends on the technology. There are also ideas and technologies resources and ideas depend on the support of politicians and this sequence continues. Obviously, the human

mind is a complex network of factors, Cannot identify the cause of the disabled and the last. "[1]

The situation with regard to the fact that "one of the most important characteristics of human decision-making and each person takes a lot during the day. Some of these decisions may be not very important and some important. [Although the responsibilities and powers of man 'takes place The decision will be more important, so as to make informed decisions and Early humans may have a substantial impact on social life, there is a strong need for techniques that can help people in this area is quite obvious." [10]

Given the attitude of human mental ability in the selection process and the decision to choose subjects beyond the simple, the complex is therefore a method based on feasibility Multiple Criteria Decision Making, called AHP Analytical Hierarchy Process or in conditions of uncertainty (fuzzy environment) Fuzzy AHP method.

This method is based on the comparison of base pairs. This means that if there are several options for making a decision on an issue all the options are to be compared together based on which one is chosen, but the options are mutually compared and results obtained at the end of the process is analyzed and the decision should be taken to select the appropriate option.

There are three levels of analytic hierarchy process in the targeted area. In the second criteria we contribute to achieving the goal posts and at the end, choose the options that are appropriate will be accepted.

2.1.4. Strategic Management:

2.1.4.1. Strategic Management "follows the same process through the organization's internal environment and its external analysis and recognition of gain, in addition, are created through its strategic direction established and strategies, that it will help to achieve predetermined goals and the strategies to implement them. "[12] Therefore, "a series of decisions and strategic management activities that determine a company's future performance. Strategic management is Environmental Assessment (both indoor and outdoor environments), Strategy (strategic planning); Strategy implementation, evaluation and control. "[11]

2.1.4.2. Strategy: Given the diversity Derived processing strategy, the following definitions can be considered to be "functionally silent strategy is the material and non-material resources to achieve sustainable competitive advantage. From the perspective of the philosophy underlying the strategy is timely diagnosis (before the competition) meet customer requirements (better than competitor) to it. In terms of process, the strategy is to create the distinguishing competencies in the organization to create value (more than rival) in the market. "[9]

The strategy can be seen as the fundamental long-term goals, adoption procedures and allocate resources to achieve these objectives must be defined. [6]

The strategy is to create an interaction with environmental factors that are often contradictory, to meet the goals of the organization. [5]

. Strategic thinking, strategic thinking detection characteristics of the competition and see the opportunities that your competitors are unaware of it. [8]

"Using the analogy of similar quality to develop new creative ideas in the definition of strategy is also another definition." [15]

"Strategic thinking, thinking, thinking and acting that includes a specific set of assumptions is] called [the purpose of replacing a potential action that challenges the assumptions." [14]

2.1.4.4. Final decision and choose the strategy: Since the strategy determines the direction of movement toward the desirable and Objectives is to increase the spatial and temporal organization in order to provide appropriate guidance. In making contingency, focus on the most appropriate strategy for the creation of strategies for an organization.

Selection of an appropriate strategy for the strategic planning process can be outlined criteria. "Some of the most prolific criteria are:

1. The use of environmental opportunities: to what extent can a strategy environmental opportunities and particularly important opportunity to respond to the environment?
2. The response to environmental threats: How can the organization of a strategy lies in the threat of environmental damage away?
3. The use of the capabilities and strengths: to what extent a strategy of capabilities and strengths of the organization to respond to opportunities and threats are analyzed?
4. The amount of compensation Weaknesses: to what extent can a strategy to improve the organization's weaknesses? "[9]

2.2. Theoretical Framework

Society will be stable should be used to provide more futuristic learning to be prepared to deal with future problems and In terms of decision-making under (time) absorb change and uncertainty that characterized the species. Therefore it is necessary taking advantage of new ways to improve the Future decisions regarding the selection process or build your own strategy or strategies.

According to the fact that strategic planning is a future approach fellowship that will lead us to the "futurists, following the discovery, creation, presentation, and analysis and evaluation of possible futures, probable and better." [3] And also know that the decisions and Policy-based strategic planning does not necessarily predict the future based on the "Decision theory as a foundation for future research of more realistic form. Making pragmatic nature and therefore not necessarily be future-oriented. Decision theory is that future orientation images Current social reality and to help determine which implies how much of the current realities in their current form can be maintained or How can a deliberate action to put them in the new plan. "Bell" and "Mao" next image [Outlook] with integrating decision theory other concepts, such as options on futures, decision, and action values have been entered into his theory. "[3] Accordingly, such an organization cannot simultaneously pursue several different strategies Need while making use of appropriate tools to select the most appropriate strategy among the strategies created to act. One of the tools in this article is cited QSPM as an analytical tool. "This tool helps the stage manager based on the data related to the utility organization] to select appropriate strategies, decisions and choices to be made." [9]

On the other hand, the material also stated that on the analytic hierarchy process there are three levels in this process so that it is targeted at the primary level. In the second criteria we contribute to achieving the goal posts and at the end, choose the options that are appropriate will be accepted.

This method is based on the comparison of paired elements. This means that if there are several options for making a decision on an issue All options can be compared together so that one is selected; but options are mutually compared and the results achieved by the end of the process is analyzed and The decision should be taken to select the appropriate option. It also follows the strategy of choice is justified, there is a principle in the strategic planning of such states "there is only one possible future, but future uncertainties may cause some to be" the next several possible strategies can be chosen in order to choose Same level options based on the analytic hierarchy process that can be paired comparison, Decision be adopted to select them. Since the circumstances of time and place in question Uncertainty associated with a fuzzy environment, we decided to accommodate contingency to apply the method of AHP and fuzzy approach.

3. Data collection and analysis

3.1. Decision-making process

We should note that our decision is based on our decisions on how our solutions to the problem area. Also, our approach to problem solving. Therefore, strategic decision-making process, the problem is the first step can be considered. If the problem definition above,

we will reach the target topic. Decision tree, aiming to end the notion that Decision-making executives to achieve it. Although the strategic management of the endpoint is not translatable as a stationary point Because the dynamics of decision-making under uncertainty is the key point of strategic management and Managers should always about issues related to the uncertainty in decision-making.

The measure aims to compare and evaluate their effectiveness e.g. cabling allows functions to be seen. If the structure is not possible to determine the effectiveness of management decisions in achieving organizational goals.

The third step toward decision-making process, identify and explore alternative strategies, and consequently the building. "Identify and explore solutions close interaction with the values, experiences, perceptions of the degree of risk managers impressive. Managers must be able to identify a balance between realities and discover ways to create jobs in the following aspects: 1) costs more information 2) the benefits of the information 3) ideal levels "[4]

One of the strategies of the human mind grab the first alternative as a last alternative. The error in the choice of solutions and options occurs accordingly, you should be careful to note that make recommendations to the stage where it is possible to generate more alternatives and options to consider and the preferred quantity over quality. But "facts obtained identification phase and discover solutions Options should produce enough information to determine the classification of solutions and the next step is to compare and evaluate solutions Although the decision, the person will explore and show the utmost, but choosing a solution options through multiple mechanisms [options] section is very sensitive Management decision-making process can be considered. "[4] So as to make the best choice decision should be trying to step on valid scientific models. One such pattern is optimized hierarchical decision analysis method.

Another point that should be considered is the best choice, problem-solving and decision-making process (see Figure 1) cannot be ignored because it is possible it is not known as innate roots and solutions have helped to resolve the problem not fundamentally solve the problem. After running through a system of monitoring and control, Feedback from the decision, analyzes, and if the decision is correct. So we see that the decision-making process is a dynamic process and has a regular cycle, the subjective and objective based on cause and effect relationship, since the decision merely indicates that the right decision is not It should be a good cycle assessment, decision feedback examined the correction of errors is necessary to make the right decision moreover, to prolong the cycle to avoid Timing can also be controlled.

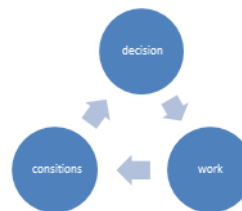

Chart 1. Process

The decision to raise the confidence of the realization of the school board should decide on the implementation of plan also to achieve results expected program possible. The decision will fail in many cases due to neglect resources as needed funds, the physical and functional, physical, manpower, lack of empowerment of supervisors for Guidance staff and a reduction in staff skills. "The decision by the structural ambiguity by definition, scope and functions that cannot be seen if on the mechanisms and efficient implementation of the remedy is not found, deemed to be worthless. The decision to become an essential part of the decision-making process is an executable program. "[4]

3.1.1. Making contingency

Emphasizes the need to strive to achieve Questions or hypotheses that explain the rules of practical projects Administrators can lead to higher fitness can be effective in the prevention of institutional crisis. Can be an effective manager by hypothesizing about the possible causes of the crisis and the intellectual power of individuals and experts Creation of a think tank of creative and use other techniques to finish the steps. Question and answer Hypothesis leads us towards the future and will cause the manager to a prospective attitude, be armed. There are several specific techniques, however, to analyze the present and future situation Strategic management is effective.

However, important decisions and rapid measures, including basic strategic management in conditions of uncertainty, but also important to determine the quality of the decision. There is no doubt good leaders, with more realism to pay the arbitration functions. We know that the uncertainty is nothing but the manifestation of all the factors that impact a state of rest or motion or order to become irregular and peace is disrupted. This condition causes the relative lack of expertise decisions based on incorrect and baseless judgments and interpretations made. The decision can be considered a system that reflects the values of the system's efficiency (Strategic decisions). It also involves making choices and while it is possible to take multiple solutions exist (in terms of multivariate decision).

Given that "perception is the process by which people thought and impression that the regulation and interpret their environment and thereby to say that... although one can perceive the reality is very different." [6] A manager should never be capable of identifying potential situations may in the future become the de facto be free. Crises occur within the same activity and the news is to inform the community, new clues can be obtained to complete a previously unknown aspects of the strategic plan.

When thinking of organizational readiness deal with the uncertainty, in fact, half of the planning for emergencies. Obviously, creative director and innovator can imagine changing conditions and complex details can be based. Speed and acceleration cause's changes even in areas of similar size and scope of the current situation are considerable differences. But this dramatic change and growth has been dramatic, causing a variety of circumstances, new possibilities has provided for the future and predict the condition in which there is no experimental reconstruction. Such features include management information systems and advanced level of intelligent systems expert noted that play a crucial role in formulating the strategy.

However, requirements of a static condition are not sedentary but the time and place can be a turbulent and changing conditions. It is important to show that the decision about these conditions must be adhered based on time and place.

Our attitude when deciding upon the overall strategic issues of strategic management new topic called focuses on making contingency opens before us. The most important result of the efforts of management decisions contingency and choice of options to suit the circumstances, contingency management is the most critical factor.

3.1.2. Model making contingency

The strategic management of the different forms of decision-making under conditions of uncertainty should be considered accordingly, the best model is the most used in strategic management in conditions of uncertainty appears to have contingency model.

In this model, the principle of unified command, on purpose, quality review and decision on selection, prioritization and comprehensive review of the process of solving problems has been emphasized.

3.2. Fuzzy AHP decision-making process and one of the most comprehensive fuzzy analytic hierarchy process Systems are designed for decision making with multiple criteria analysis of difficult and complex issues that simply convert them. This

technique allows to solve the problem formulation deals provides a hierarchical form. It is also possible to consider a variety of qualitative and quantitative criteria of the problem. This model will help people various options to shape their ideas into making decisions sensitivity analysis on the criteria and sub-criteria included the possibility. In addition, the test is based on the Judgment and facilitate the calculation of compatibility and incompatibility decision also shows that this technique is superior advantages in multi-criteria decision making. (Chart 2)

This model has a strong theoretical basis and is based on the principles of self-evident. These principles include:

Principle 1) if the opposite: if you would prefer a element is the element $b = n a$ element by element $1 / n$.

Principle 2) the homogeneity of the element with a b element should be homogeneous and comparable. In other words, a component of the element b can lead to infinity or zero.

Principle 3) the dependence of each element of the hierarchy to the top-level element to be linearly dependent and this dependence can be continued up to the highest level.

Principle 4) original expectations: Whenever a change occurs in a hierarchical structure evaluation process should be done again. [10]

The following steps should be followed to create a hierarchical structure:

- 1) Purpose of the main questions to be determined;
- 2) To identify sub-objectives;
- 3) The criteria that must be inferred secondary objectives of the main objectives, to specify the role;
- 4) determine the criteria for each of the main criteria;
- 5) At the level specified in terms of the need to specify the relevant factors involved;
- 6) Option or specify the possible consequences;
- 7) For decisions - Yes to the priority option is specified;
- 8) In most problems of creating a separate hierarchy, the benefits and costs for decision-making is very important. [1]

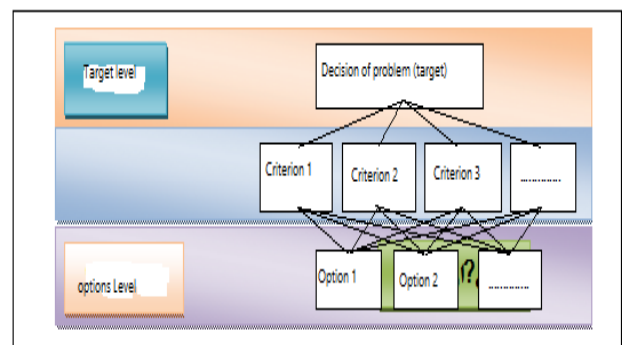

General form of Fuzzy diagram hierarchy

3.3. The process of decision making and strategic planning

It must be understood that the decision makers are those organizations that make your decision based on the combination of perception and reality. Their own perception of reality is based on interpretation and accordingly, an abstract view of the realities of the environment in their own minds.

"As the detailed description and analysis of past trends and explanation and prediction of future conditions are the basis of the status quo, perhaps all of these methods in the diagnosis of what was and what is as a background to guess about what will be, what might be, what can or what should be used." [3]

Accordingly, by analyzing the environment inside and outside your organization to identify issues or the main decision mainly on the driving forces and the key to the success or failure can be effective as well are analyzed. Classification and prioritization of key factors on the basis of two criteria of importance and uncertainty of the

next step the final strategy can be divided based on their distinguished. The ultimate goal is to develop different strategies to strategies that the differences between them are significant for decision-makers and the choice of a strategy or strategies can be considered superior to the decision makers.

Therefore the general form of contingency decisions based on the analytic hierarchy process is based on knowing more quickly which of strategy formulation and strategic planning in written emerging closer to reality and the fact that selecting from among the options presented above is important. (Figure 3)

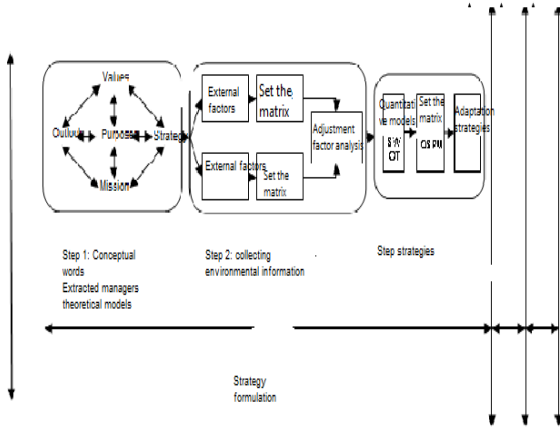
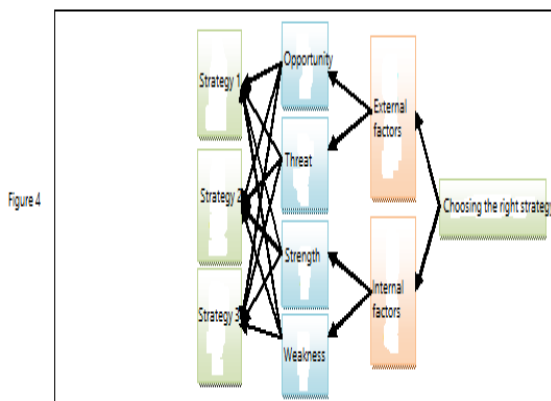

Fig. 3: Strategic planning model [13]

3.4. Adaptation of the final decision and strategy selection method based on AHP QSPM

According to Figure 1 in which step 3 is shown as an analysis strategy can be based on QSPM options strategy in terms of strategy 1, Strategy 2 placed under the weight of a paired comparison Fuzzy AHP method to choose the right strategy with the action of time and place. (Figure 4)



4. Conclusions and suggestions:

4.1. Compliance issue hoc decisions on Fuzzy AHP Strategic Planning

From the beginning to the end result, and what we say is that time and place are specific requirements in terms of uncertainty, managers will get to that variable approach, make decisions, to comply with the appropriate requirements.

Strategic planning is based on the requirements of present and potential future written and all of them can be seen and always in proportion to the accuracy of the theoretical design and mapping them, Offering various options for the next show will be possible based on fuzzy analytic hierarchy process, the options presented

and compared with each other as a couple on the basis of criteria defined by the ratio of the weight of them and finally, the desired option or options strategy in ascending or descending order, corresponding to the maximum or minimum compliance decisions of the independent variable, it was assigned to the dependent variable, and the selection of appropriate conduct.

Table 1. Fuzzy AHP decision making contingency compliance governs the process of strategic planning

Strategic planning process	Fuzzy AHP	Pattern making contingency
Explore conceptual and environmental analysis	Problem (target)	Defining the problem
Identify the key elements of environmental impact	Reformulating the problem	Benchmarking and Indicators
Analysis and classification of the "importance" and "uncertainty" (opportunities, threats, weaknesses and strengths)	Benchmarking and metrics	
Create a mental framework for theorizing proper logic and strategy (form SWOT)		
Different strategy as option	Provide options	Provide options
Mapping strategy formulation and analytical forms QSPM		
Select appropriate strategies to options and priorities based on an analytical form QSPM	Final rate calculated by summing the opinions and judgments	Choice (decision)
Measure, compare performance measures and performance targets and corrective actions	The decision to select the option or Priority	Evaluation, comparison of the conditions and criteria decision making and adopting new reform

Suggestions

Based on this proposed strategy (strategic planning) the following points as the eight steps of strategic planning in the context of uncertainty (fuzzy environment) considered:

Step One: Identify the issue or problem by exploring the conceptual and environmental analysis

Step Two: Identify the key elements that create the effect of changes in conditions of uncertainty effective.

Step Three: Analysis and classification of key environmental factors on the "importance" and "uncertainty" surrounding them opportunities, threats, weaknesses and strengths

Step Four: Create a mental framework for theorizing proper logic and strategy (analytical form SWOT)

Step Five: Developing and mapping strategy based on the options selected and mapping strategy formulation and analytical forms QSPM

Step Six: prioritize the strategies based on the measurement of the defined criteria

Seventh step: choosing the right strategy in line with the choices and priorities based on an analytical form QSPM

Step Eight: measuring, comparing the performance of selected strategies and objectives and performance criteria, corrective actions.

References

- [1] Azar, Adel and Rajabzadeh, Ali, making use Barvykrd MADM, (Fourth Edition) Tehran: look broadcasting footage of knowledge (2010).
- [2] Azar, Adel and Rajabzadeh, H., fuzzy knowledge management, (Fourth Edition) Tehran: Institute gentle book publishing, (2010).
- [3] Slaughter, Richard, for the modernity of the new millennium (concepts, methods, primary Futures), translated civil Aqeel oven, Tehran: Defence Industries Training and Research Institute, second edition (2011).
- [4] hamidizade, MR, strategic decisions and intelligent expert systems, (First Edition), Tehran: National Defense University Press, (2010).
- [5] Daft, Rychardal, the theoretical foundations of design, translation: Alwan, Mehdi, Arabs, SM, Second Edition, Tehran, cultural research center (2002).
- [6] 6-Robbins, Stephen, organization theory, organizational structure and design, translation: Alwan, Mehdi, a wise man, Hassan, thirty-first edition, Tehran, Saffar-illuminated, (2010).
- [7] Schwartz, Peter, Hnrdrvngry, planning for the future in a world of uncertainty, Zyzly born, (second edition), Tehran: Defence Industries Training and Research Institute, (2011).
- [8] Ghafarian, Wafa, "Strategic thinking" gimmick, 137, 4, 2003.
- [9] Ghafarian, loyalty, strategy 360 degrees, third edition, publisher of Industrial Management, (2014).
- [10] sacred Poor, Muhammad Hussein, Analytical Hierarchy Process AHP (Issues in Multi Criteria Decision Making), (Ninth Edition), Tehran, Amirkabir University Press, (2011)
- [11] Hangr, David J., Foundations of Strategic Management, Translation: Arabi, SM, Rezvani, Hamid Reza, Fourth Edition, Tehran: Office of Cultural Research, (201).
- [12] Harrison, Jeffrey, John Caron, Strategic Management, Translation: Ghasemi, updates, Tehran, Publications Board, (2007).
- [13] Yazdanpanah, Ahmad Ali, "Manual of developing vision of government approach" educational booklet, July 2014
- [14] Lawrence, Eton, "Strategic Thinking ", public service commission of Canada, April 27, 1999, Canada.
- [15] Sharifi, Ehsan, "Strategic thinking; a practical view", march 28,2012,Tehran.