



Vibration design for horseshoe shaped tunnel by Abaqus software

Mahdi Kasiri Ghahi¹ and Ali Sanaeirad²

1 Department of Engineering , College of Geotechnic , Khomein Branch, Islamic Azad University, Khomein, Iran

2 Department of Engineering , College of Geotechnic , Khomein Branch, Islamic Azad University, Khomein, Iran

Original Article:

Received 10 Dec. 2017 Accepted 02 Jan. 2018 Published 27 Feb. 2018

ABSTRACT

Due to the importance and diversity of tunnel designing, design of tunnel linings has been widely investigated so far. In the present paper, using (ABAQUS) for modeling tunnel under seismic and frequency load. The result of this study shows displacement and von-mises stress increase when the pressure load increase. All of models are capable to be resistant under earthquake load. The maximum displacement is about 500 mm for lining tunnel without soil structure interaction. Moreover, increasing the pressure load led to a little increase in dynamic response of the lining.

Keyword:

*Vibration design
Horseshoe
shaped tunnel
Abaqus software*

* Corresponding author: **Mahdi Kasiri Ghahi**

Peer review under responsibility of **UCT Journal of Research in Science, Engineering and Technology**

Introduction

Nowadays, a great portion of transportation is being accomplished through underground structures. As such structures are embedded into the ground and there is a remarkable interaction between them and the surrounding soil, very little attention has been paid to the impact of earthquake on these structures. Some researcher study on the behavior of tunnel structure, such as lee et al studied on the numerical modeling and analytical testing in order to evaluate an innovative space truss typed temporary structure, which is used to maintenance and repair of road tunnels [1]. Abbasi et al investigated on the numerical Investigation on Effects of Deep Excavations' Position on Existing Metro Tunnels in Urban Areas. In this study, 2D FDM software FLAC 2D was employed for modeling and investigating the effects of excavations on existing tunnels in sand layer. The cross section of tunnel is assumed as circular and tunnel exists before deep excavation and also stress relaxation in the soil body around tunnel was taken into account before installation of tunnel lining [2]. Maxim KARASEV work on the numerical analyses of tunnel, for this study using finenet element method for analyzing tunnel behavior. In this paper, variation of settlements and settlement troughs according to face and radial shield pressure are investigated [3]. Karakus et al study on the effects of different tunnel face advance excavation on the settlement by abacus software [4]. Bukaçi et al in 2016 study on the reliability analysis for tunnel supports system by employing finite element method. This research obtains a solution to how reliability analysis can be performed to design tunnel supports, by using Point Estimate Method to calculate reliability index. As a case study, is chosen one of the energy tunnels at Fan Hydropower plant [5]. Elgamal et al study on the computational modeling of cyclic mobility and post-liquefaction site response. Nevada sand at a relative density of about 40% is employed. The calibration effort focused on reproducing the salient characteristics of dynamic site response as dictated by the cyclic mobility mechanism [6]. Manouchehrian et al in 2017 studied on the rock burst in tunnels subjected to static and dynamic loads, in this study, the modeling leads to confirm that the presence of geological structures in the vicinity of deep excavations could be one of the major influence factors for the occurrence of rock burst [7]. Tiwari study on the effect of blast load on the twin tunnel. The result of this study shows that deformation in tunnel under blast decreases with increasing soil cover in between two tunnels [8]. Fan et al studied on the stress intensity factors for a tunnel containing a radial crack under compression. The results show that the numerical results using ABAQUS code and the experiment results agree well with the theoretical results [9].

1. Validation

Circular lining tunnel are considered one new approach in design of tunnels in urban structure that the basic application of that in underground spaces specially the subways, as we know, the cross-section of the tunnel is more the sensitivity to earthquakes is greater. One of the reasons of local greatness of tunnels in interactions and subway stations are this, that this article explores the

interaction between the lining of the tunnel that the results of analysis by solving theory by Einstein (1979) is compared and geometry model conditions is modeled by the Flac3d program. In this study selected strain type is a small strain as the model without holding system is applied, all movement toward the tunnel will occur with applying holding system, all movement will tend to be outside the tunnel. Elastic behavior model is the one which its situ stress is vertical 600 kPa and horizontal is 300 kPa. Tunnel is maintained with 125 mm shotcrete lining. Their research is done for both modes of interaction Lining- tunnel, a non-slip mode (no relation to shear displacement) and another is full slip (with the loss of shear stress). The results of numerical analysis are compared with presented theory solution by Schwartz theory and Einstein (1979). The main objective of the study with Flac3D application a 3-dimensional analysis of the area (period) 3000 meters of water transmission tunnel in Nosoud Kermanshah and are finding the amount of horizontal and vertical displacement. The modeling process in this project are as follows:

- ✓ modeling of the rock mass
- ✓ tunnel digging
- ✓ creation of interface between slurry and lining .obtained results from Khanjani and colleagues are as follows[1]:

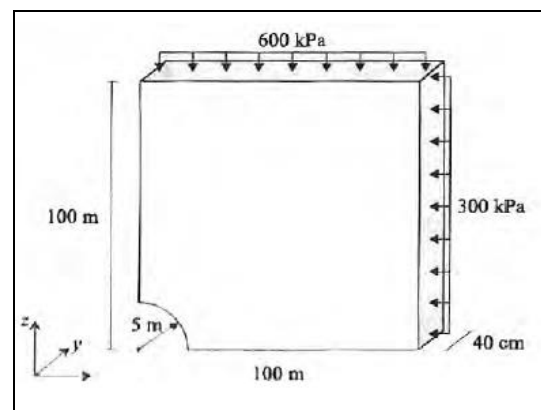
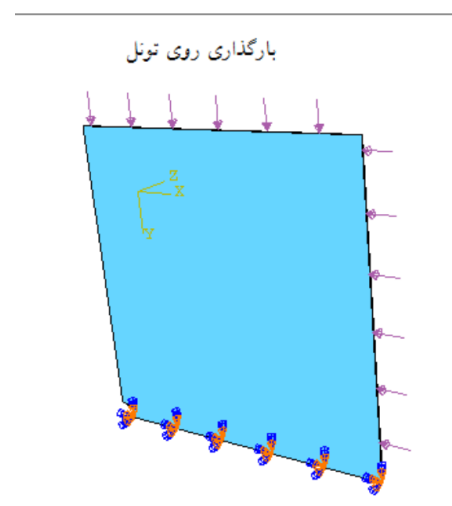

Figure 1 , tunnels dimension and pressure load



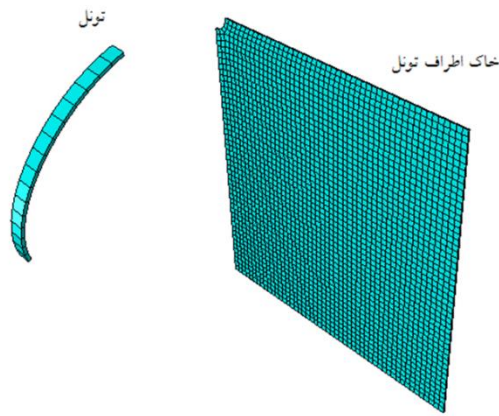

Figure 2 boundary condition and mesh model for soil and tunnel

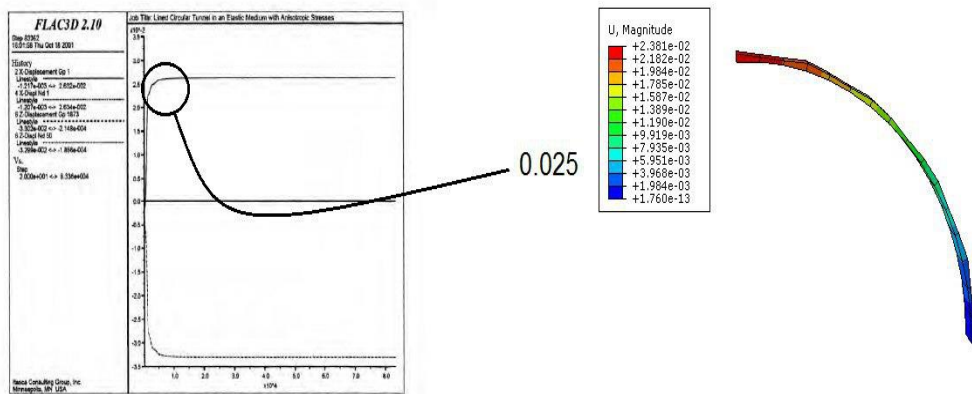

Figure3, displacement counter for tunneling

2. Results presentation

In this chapter we will consider outlines of components, materials and different stages of modeling and evaluating software outputs. Materials used and dumped and the way of modeling and variables each described. In order to assess the dynamic effects of various parameters on the side of the concrete lining is required to extract the frequency characteristics of these structures. Because natural fixed structures such as hardness, natural periodicity (frequency)

are effective in dynamic analysis. In the next section the effects of overhead or lateral pressure will investigated on the call side lining check-out. At the end of this chapter, the effects of soil modeling and effective parameters will assessed on the dynamic response of structures .In saturated soils; effective stress is used instead of the total stress. Because of this issue that water doesn't have shear strength and only are solid crystals that tolerate stress. The mechanical properties of clay are as follows:

Figure 1: elastic mechanical features and clay plastic

Special weight	elastic module (degree)	poisson quotient	angle of friction (mpa)	cohesion (KN/m3)
45	5	0.45	6	18

4-1 Mechanical properties of concrete

For concrete elastic mechanical properties (elastic modulus and Poisson's ratio) 0.15 , 23GPa values is used . Concrete curved plastic zone to push and pull, is respected like figure (3-9).

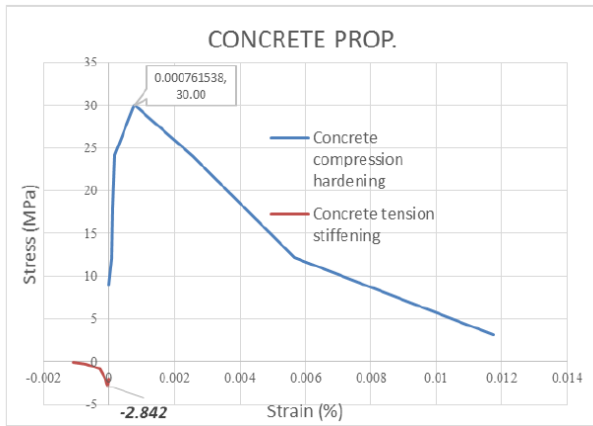

Figure 4: Concrete curved plastic zone

Among the different types of steel, steel construction tip is selected for this purpose. To use this type of steel in Abacus parameters it's necessary to do changes on this parameters.

- ✓ Assembling the components and materials allocated to them
- ✓ In models that the contact between the components should be defined, define the pair of surfaces and mechanical properties for them. Connections and interaction model
- ✓ Mesh model and assign proper structural elements suitable component
- ✓ The definition of analysis steps
- ✓ Create boundary conditions and loading

In Figures 5 related to lining models with a height of 6.5 meters and a thickness of 0.5.

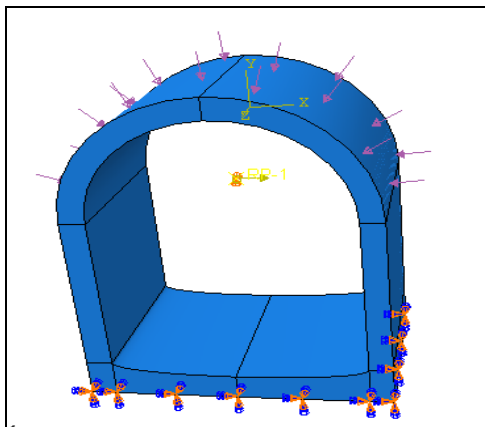

figure 5 . pressure load on the topest point of structure.

Figure 6 depicted lateral load which has been applied in the west soil layers, the earth quake load enter in this part of structure.

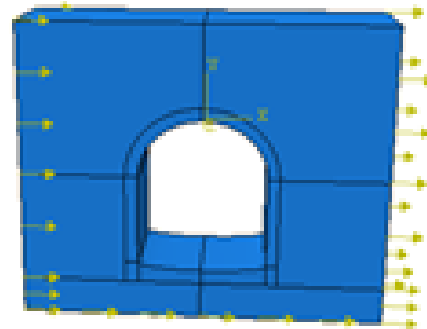

Figure 6 . earth quake load in the soil layer

Figure 7 and 8 shows lining tunnel with 6.5 m height and 0.5 thickness, the lining thickness is about 541 mm and tunnel has been located on the 4314 meter underground. The plan of tunnel and soil which has been coated tunnel shows with figure 8. Table 1 also shows all model detailing which uses for modeling tunnel in Abacus software.

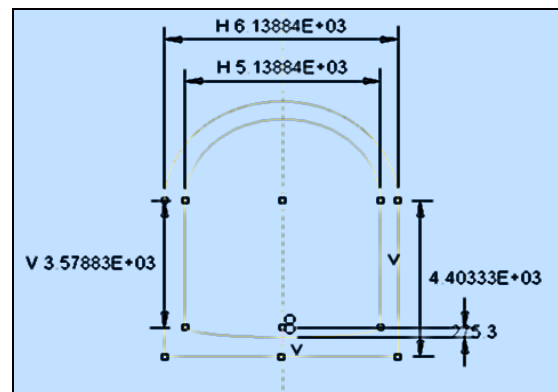

Figure 7 tunnel dimation for present study

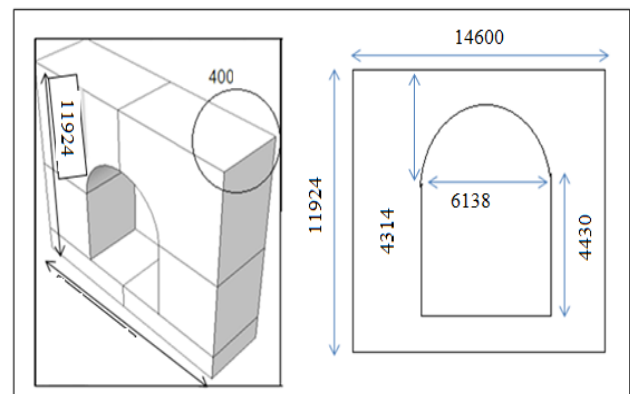

figure 8 soil dimation behind tunnel structure
Table1 soil and Tunnel dimension

Element	Wight	Leanth	Thickness
Tunnel	4053	6138	275
	3178	5138	
Soil dimension	11924	14643	400

1. The interaction between soil and tunnel assumed as frictional contact and the friction coefficient is 0.3 for all members. Using solid for modeling all structure and soil members because this element can shows structure behavior in the right ways.
2. Using wire beam for modeling reinforcement steel and this wire beam embedded on the solid concrete element.
3. Using FRP as lining layers and also using Tie as interaction for tunnel and lining layer.

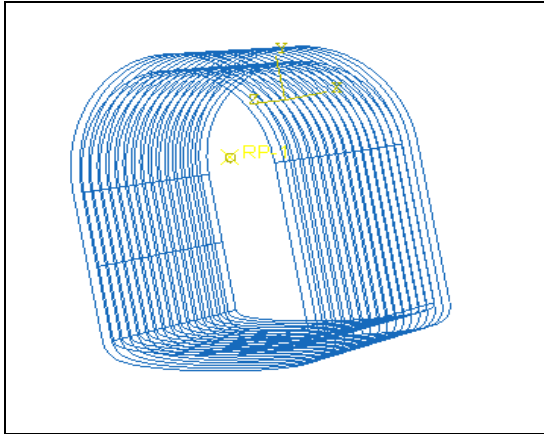

Figure 9 wire beam

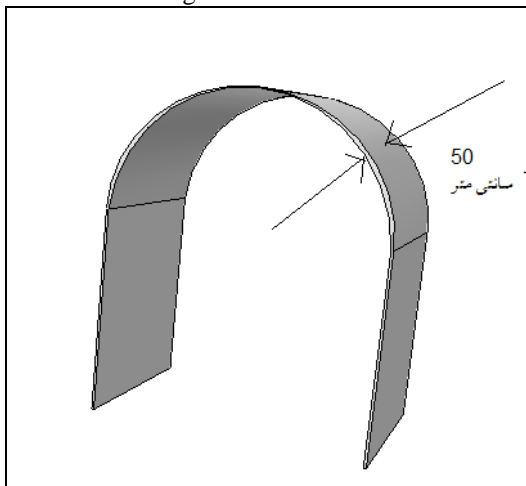

Figure 10 using FRP layer as lining

4-2 interaction between soils – structure for lining tunnel

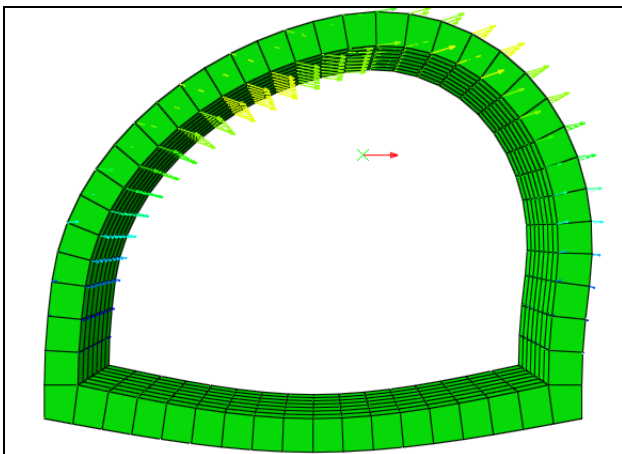

Figure 11 lateral displacement for tunnel

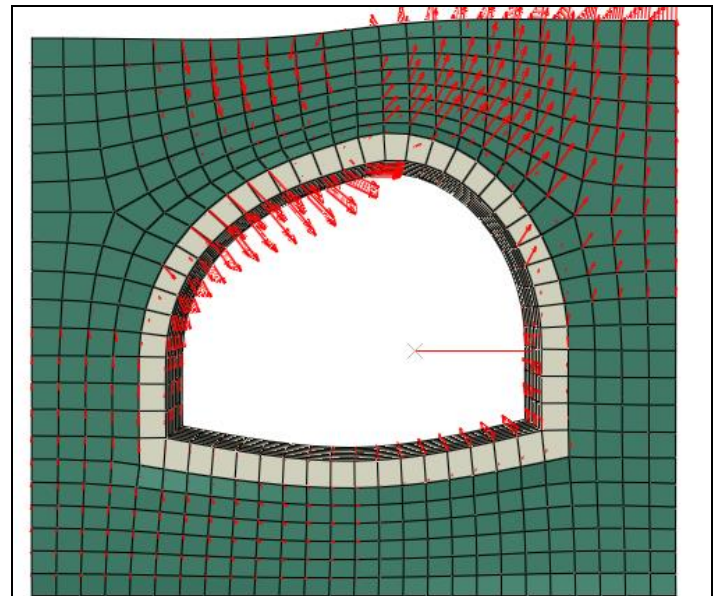

Figure 12 lateral displacement for tunnel and lining

- In the flowing, tunnel was impacted by frequency and earthquake load. History response of time lining under the pressure of both vibration with value overload of 20,40,60 KN is shown on figures 13 . According to time history of lining displacement we can say that increases in overload is increased the value of displacement of lining maximum . Displacement values are about to 130mm, 149 mm respectively in 20, 40 and 60kn.

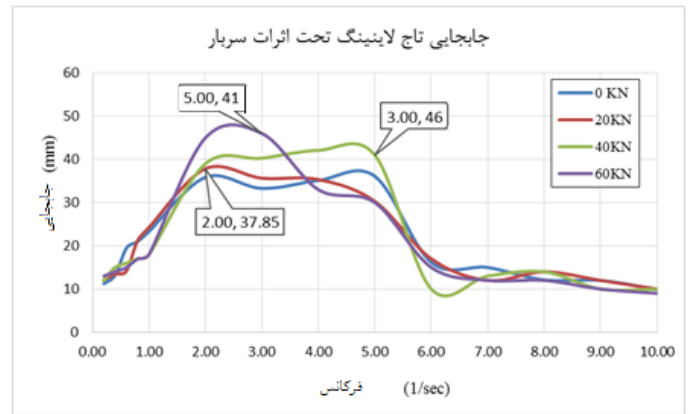

Figure 13 Effect of pressure load on the displacement
 In the present research ,two ways are applied on this tunnel, frequency and lateral loading that caused to increase of created tension in tunnel .in addition , by increasing of overload The amount of created transposition will increase in this construction . in all of transposition couriers in tunnel with shakable loading by increase of overload , the amount of transposition has been increased . transposition in the way of frequency when the overload was 60 kilo nyoton beside when the overload decreased in 20 kilo nyoton , it was evened 2.5 and the amount of created tension in tunnel by increase of overload was evened 1.39 beside to the primary state . also when it was applied to the lateral loading tunnel with shakable kind , the amount of

transposition by increase of overload was evened to 1.2 beside when the applied overload was 20 kilo nyoton.

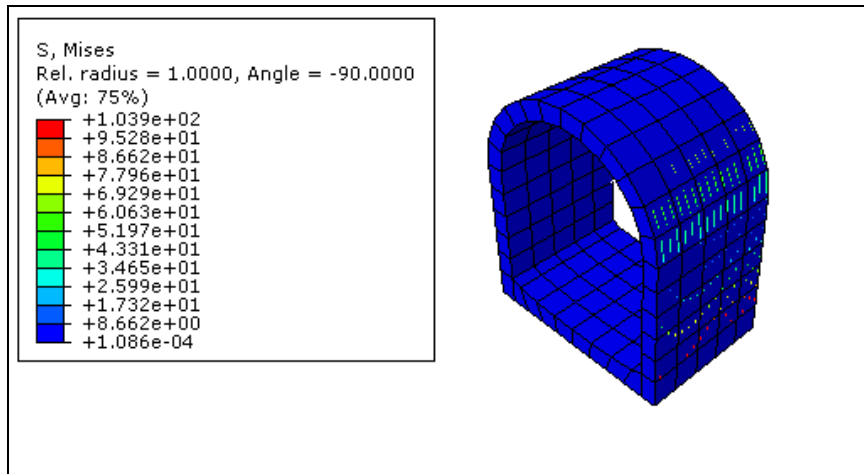

Figure 14 Effect of 20 KN pressure load on the von misses stress

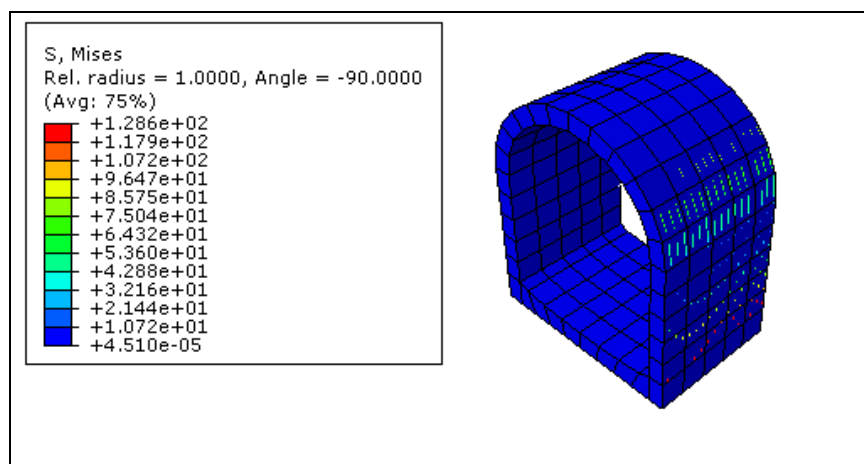

Figure 15 Effect of 40 KN pressure load on the von misses stress

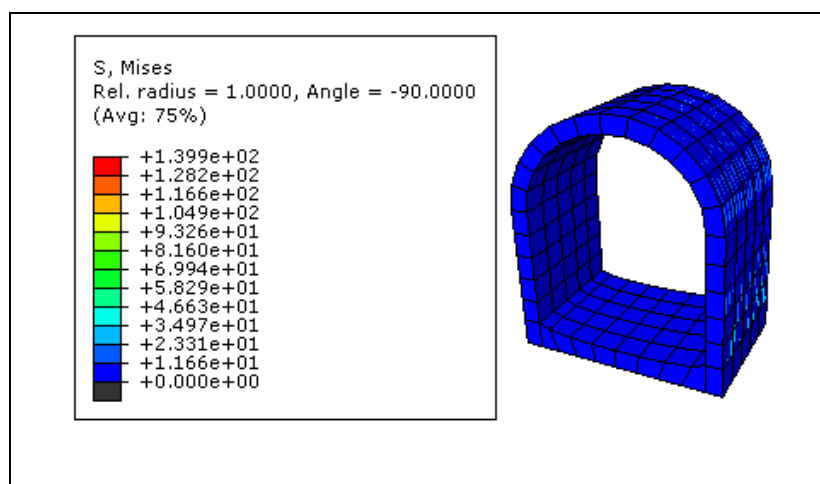

Figure 16 Effect of 60 KN pressure load on the von misses stress

5- Conclusion

- ABACUS has ability to model tunnel performance under seismic and pressure load.

- Increasing the pressure load leads to increasing displacement and von- mises stress.
- The maximum stress is 139 MPA for 60 KN pressure load and the minimum is 128 MPA which related to 20 KN.

- Displacement reaches to 500 mm when the pressure load is 60 KN and this value is 200 mm for 20 KN.

3. Reference

1. Lee, D., Kim, D., Lee, J., Noh, P., & Park, S. (2015). Analytical testing and evaluation of truss typed structures for tunnel maintenance. *Smart Structures and Systems*, 15(4), 949-961.
2. Abbasi, H., Katebi, H., & Hajjalilue Bonab, M. (2015). Numerical Investigation on Effects of Deep Excavations' Position on Existing Metro Tunnels in Urban Areas. *Advances in Railway Engineering, An International Journal*, 3(1), 15-26.
3. Karasev, M., Alexandrova, O., & Demenkov, P. (2012). Numerical analysis of tunnel induced settlement near Sagrada Familia cathedral. *Górnictwo i Geologia*, 7(1), 99-107.
4. Karakus, M., and R. J. Fowell. "Effects of different tunnel face advance excavation on the settlement by FEM." *Tunnelling and Underground Space Technology* 18.5 (2003): 513-523.
5. Bukaçi, E., Korini, T., Periku, E., Allkja, S., & Sheperi, P. Reliability Analysis for Tunnel Supports System by Using Finite Element Method.
6. Elgamal, A., Yang, Z., & Parra, E. (2002). Computational modeling of cyclic mobility and post-liquefaction site response. *Soil Dynamics and Earthquake Engineering*, 22(4), 259-271.
7. Manouchehrian, A., & Cai, M. (2017). Analysis of rockburst in tunnels subjected to static and dynamic loads. *Journal of Rock Mechanics and Geotechnical Engineering*, 9(6), 1031-1040.
8. Tiwari, R., Chakraborty, T., & Matsagar, V. (2015). Dynamic Analysis of Twin Tunnel Subjected to Internal Blast Loading. In *Advances in Structural Engineering* (pp. 343-354). Springer, New Delhi.
9. Fan, Y., Zhao, Y., Zhu, Z., Zhou, L., & Dong, Y. (2017). Stress intensity factors for a tunnel containing a radial crack under compression. *Advances in Mechanical Engineering*, 9(12), 1687814017745414.

۱۰. خانجانی م، صبا ح. ر، یوسفی راد م، مطالعه تئوریک و عددی بررسی پایداری تونلهای دایره ای لاینینگ شده در یک محیط الاستیک با تنش های انیزوتروپ، همایش ملی عمران و توسعه پایدار، ۱۳۹۱.