



Investigating the Relationship Between Human Resources Management and Organizational Citizenship Behavior Regarding the Mediator of Organizational Justice of Alborz Insurance Employees in Golestan Province

Aliyeh Salamat¹ and Hossein Didekhani^{2*}

*1*Department of Management and Accounting, Aliabad katoul Branch, Islamic Azad University, Aliabad Katoul, Iran

*2*Department of Management and Accounting, Aliabad katoul Branch, Islamic Azad University, Aliabad Katoul, Iran

Original Article:

Received 10 May, 2017 Accepted 22 Sep, 2017 Published 17 Nov, 2017

ABSTRACT

The purpose of this study was to investigate the relationship between HRM and organizational citizenship behavior with regard to the role of mediator of organizational justice among Alborz insurance staff in Golestan province. The research method used is a descriptive, survey-correlation research. The statistical population of this research includes all Alborz insurance staff in Golestan province, which is 120 people. The statistical sample was proportional to the number of people in the community, using Krejcie and Morgan table 92 and a simple random sampling method. The research data were collected using library and field method and the tools used were standard questionnaires. The reliability of the questionnaires was confirmed by the Cronbach method and the validity of the tool was confirmed by the content method. Also, for analyzing data, Structural Equation Modeling has been used using LaserLevel software. The results show that there is a significant relationship between all variables of human resource management practices and organizational citizenship behavior with regard to the role of mediator of organizational justice of Alborz insurance staff in Golestan province.

Keyword:

Human resource management, organizational citizenship behavior, organizational justice

* Corresponding author: Hossein Didehkha

Peer review under responsibility of UCT Journal of Management and Accounting Studies

Introduction

Given that human resources are a strategic resource for organizations, it is an integral part of strategic planning issues, and most organizational and human resource planning have a strategic nature. The main factors that lead to a new attitude in strategic human resource planning is the process of technological, social and economic changes in the internal and external environment of organizations that are constantly facing it. If organizations want to be in line with these changes, they must have a comprehensive, strategic approach and consider different requirements. In the present era, the most important source of competitive organizations, efficient human resources, or knowledge workers. Meanwhile, many organizations lack the expertise and skills to effectively manage strategic human resource plans. It is important to note that the development of Human resources strategies is the participation and cooperation of HR managers with the senior management of the organization. The alignment and linkage of strategies and participation and cooperation of the managers of various human resources with the senior management of the organization is the development of human resources that requires the development of human resource planning, which includes two parts:

Human Resources Strategic Management focuses on the important role of human resource management practices that emphasizes the strategic nature of human resources and the integration of HR strategies with the organization's strategy Chang, W.A., and Huang, T.C. (2016) describes HR Strategic Management as: "All activities that affect people's behavior in order to motivate them to design and implement strategic organization needs." Wright and McMahan (1992) also consider strategic human resource management as a pattern of human resource planning and activities to help the organization achieve its goals. Human Resources Strategic Management is a way to decide on the goals and objectives of the organization that relate to issues such as: employment, employee training, training, reward, and employee performance management. In fact, human resource strategic management generally addresses the relationship between HRM and strategic management of the organization (Armstrong, 2006).

From the Budhwar, P.S., and Boyne, G. (2014) the main distinction between the traditional concepts of Human resource strategic management and Human resource management is the degree of integrity of human resource management practices with the organization's strategic decision-making processes to deal with environmental changes. Bear and others (2015) argue that the competitive environment, globalization and the continuous changes in market and technology, are the main reasons for the transformation of the concepts of HRM and transforming it into strategic human resource management. The traditional concepts of HRM focus only on physical skills, specific training, specialist skills, and individual employee performance, focusing on what people were doing rather than focusing on people. While strategic human resource management, in addition to considering the above issues, emphasizes all sectors, the overall effectiveness and integrity of the organization's various activities. (Armstrong, 2006). The main objective of strategic human resource

management is to create a comprehensive perspective that allows us to address the core issues of our employees. Strategic Human Resource Management results in the organization benefiting from skilled, committed, and motivated employees in an effort to achieve sustainable competitive advantage. Its purpose is to create a sense of purposefulness and directionality in today's increasingly turbulent environments. To this end, the business needs of the organization and the individual and collective needs of its employees are provided through the design and implementation of coherent and practical HR practices and policies. In an organization with high levels of organizational learning, individuals continuously increase their ability to create the results they really deserve. Organizational learning prompts new and widespread mental patterns and individuals learn how to learn with each other on a regular basis. Organizations with such characteristics, due to the encouragement of innovation, knowledge gains, the development of capabilities, apply signals from the environment, interpret, and opt in (Beer et al, 2015). The main question of this research is whether there is a significant relationship between HRM and organizational citizenship behavior regarding the role of mediator of organizational justice among Alborz insurance staffs in Golestan province.

background research

- Azmi, F.T. (2011) The purpose of this study was to investigate the relationship between HRM actions and organizational citizenship behavior with the mediating role of organizational justice among industrial staff in China. The research method is a descriptive-correlational survey. The statistical sample was proportional to the number of people in the community using the Kerji-Morgan table of 227 and the simple random sampling method. The research data were collected using library and field method and the tools used were standard questionnaires. The reliability of the questionnaires was confirmed by Cronbach's method and the validity of the tool was confirmed by the content method. Pearson correlation coefficient was also used to analyze the data using Lisrel software. Results show that there is a meaningful relationship between HRM actions and organizational citizenship behavior with the role of mediator of organizational justice.

- Armstrong, Michael, (2006) in a research entitled Relationship between Human Resources Strategic Management and the Effectiveness of Human Resource Management and the Performance of Government Organizations in India. The research method is a descriptive-correlational survey. The data were collected using library and field method and the tools used were standard questionnaires. The reliability of the questionnaire was confirmed by the Cronbach method and the validity of the tool was confirmed by the content method. Pearson correlation test was also used to analyze the data using Lisrel software. The results show that there is a meaningful relationship between all components, strategic human resource management, and the effectiveness of human resource management and performance of government organizations in India.

- Baron, J.N., and Kreps, D.N. (1999). In a research entitled "Investigating the Simple and Multiple Relationships

between Strategic Human Resources Management and Technical Innovation". In this research, 480 faculty members from the University of Punjab have been studied by stratified random sampling. To collect data, a questionnaire of human resources strategic management functions and a technical innovation questionnaire were used. Analysis of the obtained data showed that the mean scores of human resources strategic management functions and technical innovation scores in universities were less than average and there was a significant correlation between the HRM functions and the technical innovation. Analysis of the obtained data showed that the mean scores of human resources strategic management functions and technical innovation scores in universities were less than average and there was a significant correlation between the HRM functions and the technical innovation. Also, beta coefficients between strategic HR functions and technical innovation were statistically significant and there was no linear relationship between them and regression model was significant. There were significant differences between the views of the members on the relationship between strategic HRM functions and technical innovation according to demographic characteristics.

- Becker, B.E., and Huselid, M.A. (2014), in a research entitled Relationship between Strategic Human Resource Management and Corporate Performance, which addresses the question of whether strategic performance in strategic human resource management is superior to traditional attitudes? The method of this research is descriptive. The aim is to find the relationship between the type of method used in the management of human resources of organizations and companies and their performance. Descriptive and inferential statistics were used to analyze the data using SPSS software. The research findings showed that companies pursuing strategic human resource management activities perform better than non-performing companies (traditional companies), and the use of human

resource strategic management measures and practices improves the performance of companies.

Research Methodology

Type of research method

This research is, in terms of its nature and purpose, of the type of applied research. An applied research is an attempt to address a problem and the scientific problem that exists in the real world (Khaki, 1382: 94) And in terms of how data is collected, a descriptive survey is a type of survey, and because the hypotheses used are relationship or correlation, in which the relationship and the direction of correlation between variables are examined, so the research method is descriptive / Surveying and Solidarity.

Method of data collection

The method of data collection was conducted in two ways: library and field studies.

Information gathering tool

In this research, the questionnaire is used as a research tool in relation to the subject matter and the research method that is a survey. In this research, standard questionnaires were used to measure the variables of the research. To measure the actions of human resources management measures, the standard questionnaire on measures of human resources management measures (Armstrong, 1998) has been used to assess organizational justice using organizational justice standard questionnaire (Novohof and Morman, 2001).

Information analysis method

1. Descriptive statistics will be used for estimating the central characteristics and setting the frequency distribution tables.

2. Inferential statistics are used to test the hypotheses. It should be noted that statistical analyzes are usually used to generalize the results of the research. In the present study, structural equation tests are used to analyze the data with the help of lisrel software (Bost, John, 2005).

Test of research hypotheses

In this section, we examine the test of research hypotheses using Lisrel software.

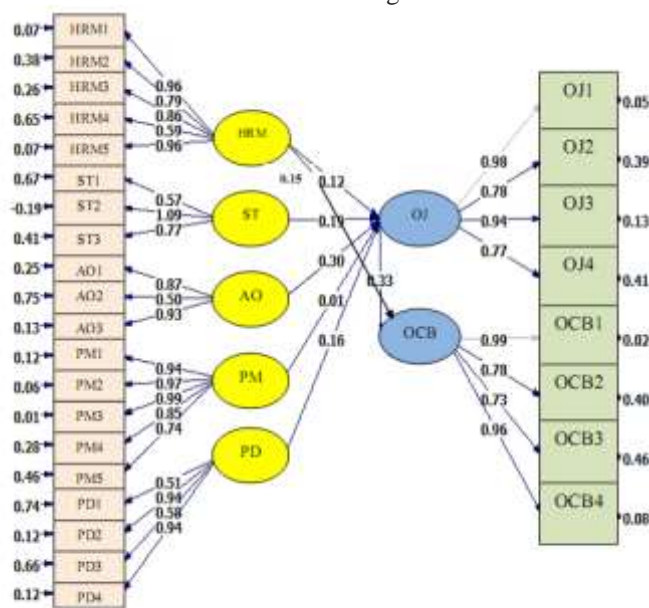

Chi-Square=1013.62, df=344, P-value=0.00000, RMSEA=0.073

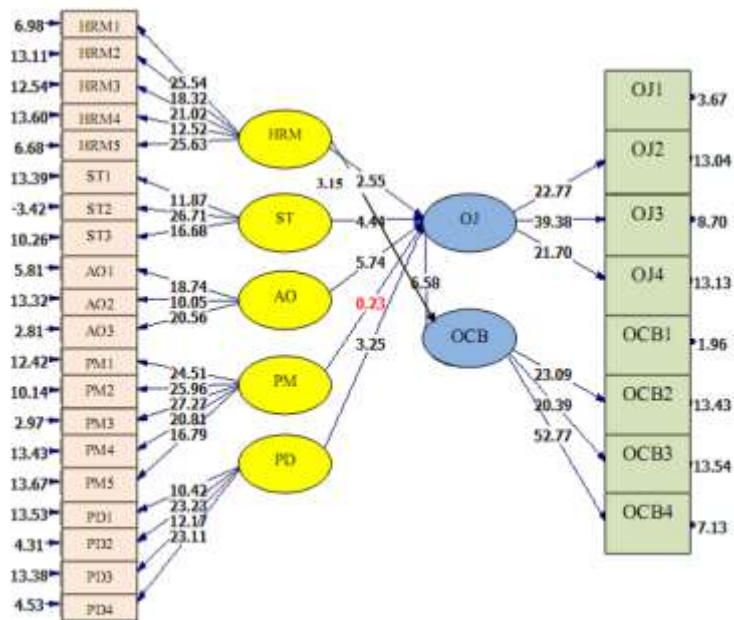

Chi-Square=1013.62, df=344, P-value=0.00000, RMSEA=0.073

Direct relationship and significance coefficients of model hypothesis

Test result	meaningful	Path coefficient	sign	Direction
Accept	2.55	0.12	HRM---OJ	Organizational Justice --- HRM actions
Accept	3.15	0.15	HRM---OCB	Behavioral organization --- HRM actions
Accept	4.44	0.19	ST --- OJ	Organizational Justice --- Staff selection
Accept	5.74	0.30	AO --- OJ	Organizational Justice --- Promotional opportunities
Reject	0.23	0.01	PM --- OJ	Organizational Justice --- performance management
Accept	3.25	0.16	PD --- OJ	Organizational --- Participation in decision making Justice
Accept	6.58	0.33	OJ --- OCB	Behavioral organization --- Organizational Justice

Discussion and Conclusion The results of research hypotheses:

Hypothesis 1 There is a meaningful relationship between HRM actions and organizational justice of the Alborz insurance staff in Golestan province.

According to the table, the coefficient of the relationship between HRM actions and organizational justice is 0.12. The statistic for this coefficient is also 2.55 and its value is higher than the meaning threshold of 1.96. With regard to the above, it can be concluded that HRM actions with organizational justice have a positive and meaningful relationship. Therefore, the first hypothesis of this research is confirmed.

Hypothesis 2 There is a significant relationship between HRM actions and organizational citizenship behavior of Alborz insurance staff in Golestan province.

According to Table 4-11, the coefficient of the relationship between HRM actions and organizational citizenship behavior is 0.15. The T-statistic for this coefficient is also 3.15 and its value is above the meaningful threshold of 1.96. Considering the above, it can be concluded that HRM measures with organizational citizenship behavior have a positive and meaningful relationship. Therefore, the second hypothesis of this research is confirmed.

Hypothesis 3: There is a significant relationship between the selection of human resources and the organizational justice of the Alborz insurance staff in Golestan province.

As indicated in the table, the path coefficient between the selection of human resources and organizational justice is 0.19. The T-statistic for this relationship is 4.44 and its value is above the meaning threshold of 1.96. With regard to the above, it can be concluded that the selection of human resources with organizational justice has a meaningful relationship. Therefore, the third hypothesis of this research is confirmed.

Hypothesis 4. There is a meaningful relationship between advertising opportunities with organizational justice of Alborz insurance staff in Golestan province.

The fitted model shows that the path coefficient between advertising opportunities with organizational justice is 0.30. Since the value of t for this coefficient is 5.74 and its value is above the meaningful threshold of 1.96, it can be concluded that the obtained coefficient is meaningful. In other words, advertising opportunities with organizational justice have a positive and meaningful relationship. Therefore, the fourth hypothesis of the research is confirmed.

Hypothesis 5. There is a meaningful relationship between performance management and organizational justice of Alborz insurance staff in Golestan province.

According to the table, the coefficient of the relationship between performance management and organizational justice is 0.01. The statistic for this coefficient is also 0.23, and its value is lower than the meaning threshold of 1.96. Therefore, performance management with organizational justice is not meaningful. Therefore, the fifth hypothesis of the research is not confirmed.

Hypothesis 6. There is a significant relationship between participation in decision making and organizational justice of Alborz insurance staff in Golestan province.

The fitted model shows that the coefficient of the relationship between participation in decision making and organizational justice is 0.16. The T-statistic for this coefficient is also 3.25 and its value is higher than the meaningful threshold of 1.96. In other words, participation in decision making has a positive and meaningful relationship with organizational justice. Therefore, the sixth hypothesis of the research is also confirmed.

Hypothesis 7. There is a significant relationship between organizational justice with organizational citizenship behavior of Alborz insurance staff in Golestan province.

The fitted model shows that the amount of path coefficient between organizational justice and organizational citizenship behavior is 0.33. The statistic for this coefficient is also 6.58 and its value is above the meaning threshold of 1.96. In other words, organizational justice has a positive and meaningful relationship with organizational citizenship behavior. Therefore, the seventh hypothesis of the research is also confirmed.

References

- Azmi, F.T. (2011), "Strategic human resource management and its linkage with HRM effectiveness and organizational performance: evidence from India", *The International Journal of Human Resource Management*, Vol. 22, No. 18, November 2011, 3888–3912.
- Armstrong, Michael, (2006) *A Handbook of Human Resource Management Practice*, Kogan Page.
- Baron, J.N., and Kreps, D.N. (1999), *Strategic Human Resource Management: Framework for General Managers*, New York: John Wiley & Sons
- Becker, B.E., and Huselid, M.A. (2014), 'High Performance Work Systems and Firm Performance: A Synthesis of Research and Managerial Applications,' in *Research in Personnel and Human Resource Management*, ed. G.R. Ferris, Greenwich, CT: JAI Press, pp. 53–101..
- Bee r, M., Spector, B., Lawrence, P.R., Mills, D.Q., and Walton, R.E. (2015), *Managing Human Assets*, New York: The Free Press.
- Budhwar, P.S., and Boyne, G. (2014), 'Human Resource Management in the Indian Public and Private Sectors: An Empirical Comparison,' *The International Journal of Human Resource Management*, 15, 2, 346–370.
- Budhwar, P.S., and Sparrow, P.R. (2014), 'Evaluating Levels of Strategic Integration and Devolvement of Human Resource Management in India,' *The International Journal of Human Resource Management*, 8, 4, 476–494
- Chang, W.A., and Huang, T.C. (2016), 'Relationship Between Strategic Human Resource Management and Firm Performance: A Contingency Perspective,' *International Journal of Manpower*, 26, 5, 434–449..