



The relationship between strategic human resource management and job performance with the role of knowledge management Sayyad Shirazi hospital staff Gorgan

Neda Reyazi¹ and Ali Akbar Aghaei^{2}*

*1*Department of Management and Accounting, Aliabad katoul Branch, Islamic Azad University, Aliabad Katoul, Iran

2. Department of Golestan University, Gorgan Branch, Gorgan, Iran

Original Article:

Received 30 Jan. 2017 Accepted 05 April. 2017 Published 20 May. 2017

ABSTRACT

The aim of this study was to investigate the relationship between strategic human resource management and job performance with the role of knowledge management is the hospital staff Sayyad Shirazi Gorgan. The research method used descriptive, correlational survey research. The target population included all Sayyad Shirazi Gorgan hospital staff to 600 people. The sample is proportional to the number of people using Morgan table, 234 people were selected by simple random sampling. The research data were collected by library and field methods and tools used standard questionnaires. Cronbach's reliability and validity of the method of using content approved have taken. In order to analyze the data, structural equation modeling using LISREL software has been used. The results show that the strategic management of human resources with job performance with the role of knowledge management There is a significant relationship between hospital staff Sayyad Shirazi Gorgan.

Keyword:

strategic human resource management, job performance, knowledge management

* Corresponding author: *Ali Akbar Aghaei*

Peer review under responsibility of **UCT Journal of Management and Accounting Studies**

Introduction

Given the dramatic changes in social and organizational environments intensifying competition in the world today more than ever, organizations are looking to attract and More importantly, the preservation and development of their people for current and future processes. Organizations are looking for new capital as human capital, to say that human capital is a factor which more than any other factor affecting the growth and survival is. The importance of human capital has expanded in all fields, so that modern growth theory to regard human capital accumulation and Even human capital as an influential factor in the economic development of the communities considered (Armstrong, 2006).

Given that the novel human capital topics in human resources is a strategic issue for organizations is increasing in organizations and societies. In short, human capital plays an important role in the prosperity of the people, improve living standards and income, increasing knowledge and skills, capacities, production, economic growth and reduce poverty. Due to recent developments, future research in the field of human capital has two The aim is, first, to assess gaps in human capital pays off. Second, how human capital to productivity and income leads more. Due to the fact that employees and human capital into their own professional purposes Instead expenses that do reward their investment in human capital through wages, benefits, job satisfaction inherent Which invested much of its resources on education and training of human resources are the most important and rarest source (Azmi,F.T.(2011).

Given the importance of human resources in organizations in this study was to investigate the relationship between strategic human resource management and job performance with the role Knowledge management is an hospital staff Sayyad Shirazi city of Gorgan.

Statement of the problem

Since human resources are the most valuable production factor and the most important asset of any organization and the main source of competitive advantage and causing germ capabilities of any organization, One of the major organizational planning, human resource planning. An important factor for the existence of human resources planning, planning to meet the needs of skills, education and human resource development ultimately.

The most effective way to achieve a competitive advantage in today's enterprise through improvement of their employees and what direction Human resource development is important is to improve the human resources can not be acquired only with technical training but also multiple ways to develop employees' pay This important component of the strategic management of the realm of human resource management will be possible. Baron, J.N., and Kreps, D.N. (2008).

One of the most important and most basic activities in order to keep the positive changes in the society healthy and competitive ability Systems of improvement and innovation in human resources in order to achieve the desired goals and the manufacturer's organization. In a sense, you could say: "this age changes, and the man of today has undergone waves of change, the world as the ocean waves become waves changes every moment aboard a boat that world we

call the hand that way and at any age in life so changing it is not human." (Kelly, J., and Gennard, J. (1996).

Of the most important factors of economic development and social at different times depending on the role and effectiveness of human resources because humans, unlike other beings as creative and efficient that can make your work in terms of quantitative and qualitative promoted and developed new methods to overcome the problems. Trained manpower and skilled can belong to the power of your thinking and make the most of its available resources (Becker, B.E., and Huselid, M.A. (2010). The fact is that if organizations are creative people, knowledge workers, opportunity recognition and Tbyyn-Gr benefit issues, many of the opportunities and situations to lose. For Globalization goal or even stay at this level, breeding and replacement of new forces in order to continue the growth and development is essential And the future belongs to those for which the program and the target.

Since human resources, strategic resource for organizations is among the most important and essential issues of strategic planning and organizational planning and human resources are of strategic nature. The main factors that led to a new approach in the strategic planning of human resources and process changes Technological change, social and economic internal and external environments of organizations are constantly faced with. If organizations want these changes should be consistent with the comprehensive and strategic approach and consider various requirements. At present, the major source of organizational competitiveness, human resource Skilled or knowledge workers themselves. However, many organizations lack the expertise and skills are needed to be able to effectively provide human resource strategic plans.

The important point is that human resource strategies necessary for the formation of partnerships and co-director of human resources with senior management of the organization. Align and bond strategies and cooperation in various fields of human resource managers, senior management, human resource development creates Which requires planning, human resource development, which includes two components:

Strategic human resource management, human resource management is based on the important role that the strategic nature of human resources and organizational strategy focuses on integrated human resources strategy. Schuler (1992) Strategic Human Resource Management, describing it as "all activities that influence people's behavior in inciting them to design and implement the strategic needs of the organization." Wright and McMahan (1992) Management Strategic human resource allocation pattern of planned human resource and activities intended to help the organization realize its goals. Strategic Human Resource Management, an approach to decision-making about the intentions and plans of the issues, such as: employment, recruitment, training, compensation and performance management staff are concerned. In fact, the strategic management of human resources in general to the relationship between human resource management and strategic management of the organization concerned (Armstrong, 2006).

The main distinction between traditional concepts of human resource management and strategic management of human resources, from the perspective of August (1987) the integration of human resources management with strategic decision-making processes of the organization in order to cope with environmental changes. Traditional concepts of human resource management only physical skills, Special education, special skills and performance of individual employees and emphasized instead pay attention to people, to things that were done by the people, was the focus. While the strategic management of human resources, in addition to the above, in all sectors, knowledge management and integration of various activities The organization emphasized. (Armstrong, 2008) The main purpose of the strategic management of human resources, create a macro perspective, the possibility of addressing the underlying issues of staff provided. Strategic Human Resource Management Organization would benefit from skilled staff, committed And motivated in their efforts to achieve sustainable competitive advantage is its purpose, a sense of purpose and directed in environments often turbulent today so that the business needs of the organization and the needs of the individual and group staff of the design and implementation of programs and policies are coherent and human resource functions to be provided. Organizations with high levels of organizational learning, They joined their ability to create results they truly desired to increase. Organizational learning makes new mental models and develop extensive and regular people learn how to learn together. Organizations with such characteristics is due to encourage innovation, knowledge, develop capabilities, signals received from the environment, and the opportunity to exert interpretation (Beer, M., Spector, B., Lawrence, P.R., Mills, D.Q., and Walton, R.E. (2013).

Knowledge management involves identifying and determining the intellectual capital of an organization, new knowledge to maintain competitive advantage of the organization, provide access to large amounts of information, sharing of best performance by using technology that make all of the above is possible . In general, it can be Knowledge management can be said as the organization knowledge, trying to gain the necessary knowledge, information sharing within the organization and emphasis on Strengthening institutional memory in order to improve decision-making process, increase production and support innovation in the organization. (Budhwar, P.S., and Boyne, G, (2012).

Veneration any person in any situation where the marker insight that person to that position or special issue in which it is evaluated with regard to organizational learning individuals, represents knowledge and awareness of people about the factors affecting Therefore, organizational learning organization can be one of Factors affecting organizational health of the individual within the organization. Budhwar, P.S., and Sparrow, P.R. (1997), believe that strategic human resource management framework should be of widespread, contingency, and create integrated. HRM strategy to create maximum coordination and cooperation between employees and the organization. Increasing Complexity, groups can better work. Now a growing number of companies have turned to the use of autonomous work groups Research shows that the use of working groups leading to increased quality and

efficiency. Due to increasing attention to strategic human resource management tries to be examined in relation to job performance and knowledge management staff. The main research question is whether the strategic management of human resources and job performance With the role of knowledge management There is a significant relationship between hospital staff Sayyad Shirazi Gorgan?

Hypotheses

- between strategic human resource management and knowledge management Sayyad Shirazi hospital staff Gorgan there is a significant relationship.
- the strategic management of human resources with job performance Sayyad Shirazi Hospital in Gorgan, there is a significant relationship.
- the role and position of human resources and knowledge management Sayyad Shirazi hospital staff Gorgan there is a significant relationship.
- the strategy of human resource management and knowledge management Sayyad Shirazi hospital staff Gorgan there is a significant relationship.
- between internal knowledge management strategy Sayyad Shirazi hospital staff Gorgan there is a significant relationship.
- External knowledge management strategy Sayyad Shirazi hospital staff Gorgan there is a significant relationship.
- between knowledge management and job performance Sayyad Shirazi Hospital in Gorgan, there is a significant relationship.
- the strategic management of human resources with job performance with the role of knowledge management There is a significant relationship between hospital staff Sayyad Shirazi Gorgan.

Research methodology

The methodology of this research is descriptive and correlational survey. In terms of monitoring and control level of this study is among the research field. Applied research and scientific problems is an attempt to respond to a problem that exists in the real world (Earth, 1382: 94).

The data collection

The data collection was done in two ways Athletics library.

Data collection

This study investigated the matter and methods according to the survey questionnaire used as research tools. In this study, standard questionnaires to measure the variables used in the study. Strategic human resource management from a standard questionnaire to assess strategic human resource management (Armstrong, 1998), to measure job performance questionnaire (consist, 2000) and to assess knowledge management questionnaire (Lawson, 2000) was used.

Methods for data analysis

Data analysis in this study are the following:

1. Descriptive statistics for evaluation of central and adjust the frequency tables were used.
2. inferential statistics (ANOVA) to test the hypotheses used. It should be recognized that in order to generalize the results of the test are usually used. In the present study data analysis using software Lisrel test is used structural equation.

The population sample size and sampling

The population in the study of Gorgan Sayyad Shirazi hospital staff to 600 employees. The sample of the study of Gorgan Sayyad Shirazi hospital

staff to 234 employees. Simple random sampling method, according to Morgan table is obtained. Since the probability of return of the questionnaires was therefore 10% of the total of 260 questionnaires were distributed.

Test hypotheses

In this part of the test hypotheses using the software we Lisrel.

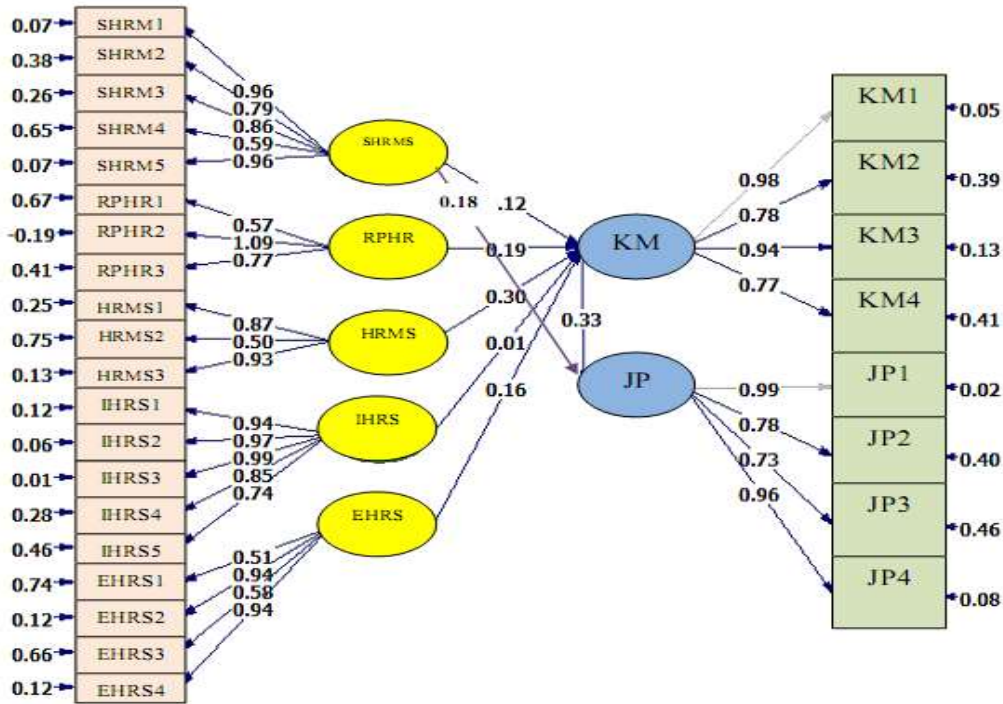

Chi-Square=1013.62, df=344, P-value=0.00000, RMSEA=0.073

Figure 4.1 Structural Model Research in standard mode

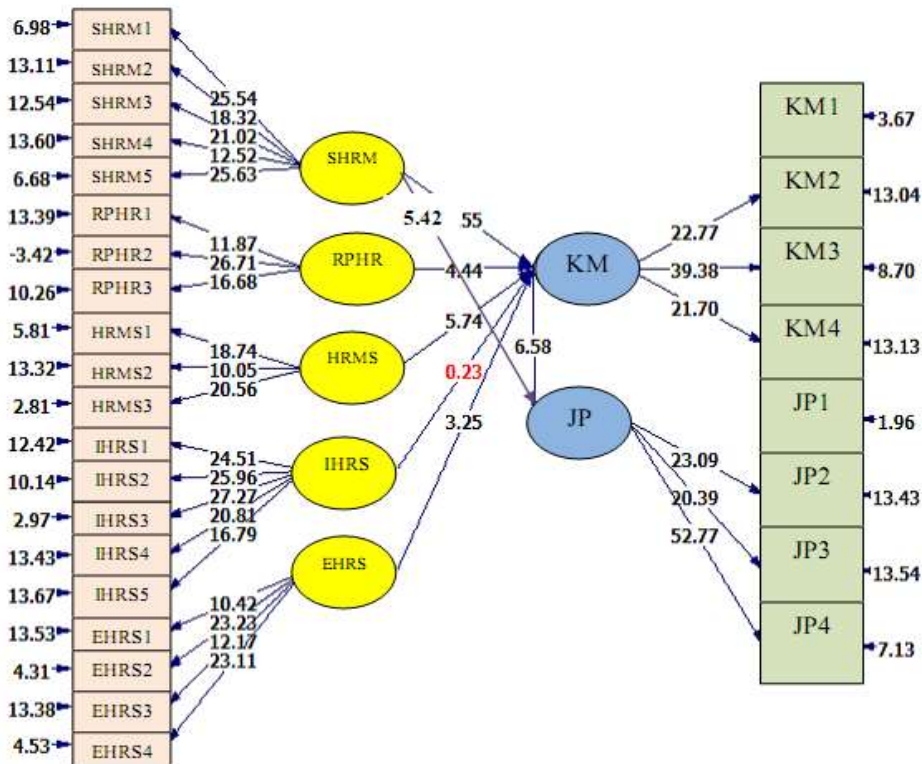

Chi-Square=1013.62, df=344, P-value=0.00000, RMSEA=0.073

Figure 4.2 In the case of significant structural model study

Table 4-11- relationship results in direct and meaningful coefficients model assumptions

Test result	meaningful	Path coefficient	sign	Direction
Acceptable	2.55	0.12	SHRM---KM	Strategic Management of Human Resources --- knowledge management
Acceptable	5.42	0.18	SHRM---JP	Strategic Management of Human Resources --- Job Performance
Acceptable	4.44	0.19	RPHR---KM	The role and position of human resources --- knowledge management
Acceptable	5.74	0.30	HRMS---KM	Human resources management strategy --- knowledge management
Rejection	0.23	0.01	IHRM---KM	Internal human resource strategy --- knowledge management
Acceptable	3.25	0.16	EHRM---KM	External human resources strategy --- knowledge management
Acceptable	6.58	0.33	KM ---JP	knowledge management --- Job Performance

DISCUSSION

Hypothesis 1. Between strategic human resource management and knowledge management Sayyad Shirazi hospital staff Gorgan there is a significant relationship.

According to Table 4-11 can be said of the relationship between strategic human resource management and knowledge management path coefficient is 0.12. Statistic for this coefficient is 2.55 and its value is also higher than the 96.1 achieved a significant threshold. Based on the above it can be concluded strategic human resource management and knowledge management there is a significant positive relationship. The first hypothesis of this study is an approved.

Hypothesis 2: the strategic management of human resources with job performance Sayyad Shirazi Hospital in Gorgan, there is a significant relationship.

As is shown in Table 4-11, the path coefficient of 0.18 is achieved strategic human resource management and job performance. T for the amount above the threshold of a significant relationship between 5.42 and 1.96 is obtained. Based on the above it can be concluded the strategic management of human resources is a significant relationship with job performance. The second hypothesis is an approved this study.

Hypothesis 3: the role and position of human resources and knowledge management Sayyad Shirazi hospital staff Gorgan there is a significant relationship.

As is shown in Table 4-11, the path coefficient between human resources management role and position of 0.19 is obtained. T for the amount above the threshold of a significant relationship between 4.44 and 1.96 is obtained. Based on the above it can be concluded and the appropriate position of human resources has a significant relationship with knowledge management. The third hypothesis of this study confirm the result.

Hypothesis 4. Between human resource management and knowledge management strategy Sayyad Shirazi hospital staff Gorgan there is a significant relationship.

Model shows the path coefficient between HRM strategy and knowledge management is 0.30. Since the value for this ratio, the higher the threshold of a significant amount of

5.74 and 1.96 is obtained, it can be concluded that the coefficient obtained is the Mna-Dar. In other words, human resource management and knowledge management strategy is a significant positive relationship. The research confirms the hypothesis fourth-be.

Hypothesis 5. of human resources and knowledge management strategy Sayyad Shirazi hospital staff Gorgan there is a significant relationship.

According to Table 4-11 can be said of the relationship between internal strategy, human resources and knowledge management path coefficient is 0.01. Statistic for this coefficient is 0.23, and the value is significantly below the threshold of 1.96 is obtained. The strategy of human resource and knowledge management relationship is not significant. The fifth research hypothesis can not be confirmed.

Hypothesis 6 between the external strategy, human resources and knowledge management Sayyad Shirazi hospital staff Gorgan there is a significant relationship.

The path coefficient of the fitted model shows the relationship between external strategy, human resources and knowledge management 0.16. Statistic for this coefficient is 3.25 and its value is significantly higher than the threshold of 1.96 is obtained. In other words, external strategy, human resources and knowledge management relationship is mean-you. The sixth research hypothesis is confirmed.

Hypothesis 7. between knowledge management and job performance Sayyad Shirazi Hospital in Gorgan, there is a significant relationship.

The path coefficient of the fitted model shows the relationship between knowledge management and job performance is 0.33. Statistic for this coefficient is 6.58 and its value is significantly higher than the threshold of 1.96 is obtained. In other words, knowledge management is a positive and significant relationship with job performance. The study confirmed the hypothesis placed seventh.

Hypothesis 8. The strategic management of human resources with job performance with the role of knowledge management There is a significant relationship between hospital staff Sayyad Shirazi Gorgan.

Fitted model shows the path coefficient between strategic human resource management and knowledge management staff and the value for this coefficient is 0.12, 2.55, and its

value is significantly higher screw threshold of 1.96 is obtained. The path coefficient and t value obtained for the relationship between knowledge management and job performance, respectively, 0.33 and 6.58 respectively. So it can be concluded between strategic human resource management and job performance through knowledge management, and a significant positive relationship.

references:

- Azmi, F.T. (2011), "Strategic human resource management and its linkage with HRM effectiveness and organizational performance: evidence from India", *The International Journal of Human Resource Management*, Vol. 22, No. 18, November 2011, 3888–3912.
- Armstrong, Michael, (2006) *A Handbook of Human Resource Management Practice*, Kogan Page,.
- Baron, J.N., and Kreps, D.N. (2008), *Strategic Human Resource Management: Framework for General Managers*, New York: John Wiley & Sons
- Becker, B.E., and Huselid, M.A. (2010), 'High Performance Work Systems and Firm Performance: A Synthesis of Research and Managerial Applications,' in *Research in Personnel and Human Resource Management*, ed. G.R. Ferris, Greenwich, CT: JAI Press, pp. 53–101..
- Beer, M., Spector, B., Lawrence, P.R., Mills, D.Q., and Walton, R.E. (2013), *Managing Human Assets*, New York: The Free Press.
- Budhwar, P.S., and Boyne, G. (2012), 'Human Resource Management in the Indian Public and Private Sectors: An Empirical Comparison,' *The International Journal of Human Resource Management*, 15, 2, 346–370.
- Budhwar, P.S., and Sparrow, P.R. (1997), 'Evaluating Levels of Strategic Integration and Devolvement of Human Resource Management in India,' *The International Journal of Human Resource Management*, 8, 4, 476–494
- Chang, W.A., and Huang, T.C. (2005), 'Relationship Between Strategic Human Resource Management and Firm Performance: A Contingency Perspective,' *International Journal of Manpower*, 26, 5, 434–44.
- Green, K.W., Cindy, W.H., Whitten, D., and Medlin, B. (2006), 'The Impact of Strategic Human Resource Management on Firm Performance and HR Professionals' Work Attitude and Work Performance,' *International Journal of Human Resource Management*, 17, 4, 559–579.
- Guest, D. (1987), 'Human Resource Management and Industrial Relations,' *Journal of Management Studies*, 24, 5, 503–521
- Gurbuz, S. and Mert, I.S. (2011), Impact of the strategic human resource management on organizational performance: evidence from Turkey. *The International Journal of Human Resource Management*. Vol. 22, No. 8, April 2011, 1803–1822,
- Kelly, J., and Gennard, J. (1996), 'The role of Personnel Directors on the Board of Directors Personnel Review,' 25, 1, 7–24.
- Khatri, N. (2000), 'Managing Human Resource for Competitive Advantage: A Study of Companies in Singapore,' *International Journal of Human Resource Management*, 11, 2, 336–365.