



The Relationship between Quality of Work Life and Spiritual Intelligence in the Department of Welfare of Golestan Province

Khadijeh Tahmasbi Yasavoli

Department of Management and Accounting, Aliabad katoul Branch, Islamic Azad University, Aliabad Katoul, Iran

Original Article:

Received 01 March, 2017 Accepted 10 MArch, 2017 Published 7 July, 2017

ABSTRACT

The aim of this study was to investigate the relationship between quality of work life and spiritual intelligence in the Welfare Organization is the Golestan Province . The research methodology was descriptive, correlational research is survey. The target population included all employees of the Department of Social Welfare city Golestan Province dome 57 Summary. The aim of this study was to investigate the relationship between quality of work life and spiritual intelligence in the Welfare Organization is the Golestan Province . The research methodology was descriptive, correlational research is survey. The target population included all employees of the Department of Social Welfare city Golestan Province dome 57 People. The sample was selected due to limited population census methods. Library and field research data were collected using standard questionnaires and tools are used. The reliability of the questionnaire using Cronbach and validity have been confirmed by the content. In order to analyze the data, structural equation modeling using LISREL software used People. The sample was selected due to limited population census methods. Library and field research data were collected using standard questionnaires and tools are used. The reliability of the questionnaire using Cronbach and validity have been confirmed by the content. In order to analyze the data, structural equation modeling using LISREL software used Is. The results show that, between the quality of work life and spiritual intelligence in the Golestan Province there is a significant welfare organization.

Keyword:

quality of work life,
spiritual intelligence,
Welfare Organization
Golestan Province

*** Corresponding author**

Khadijeh Tahmasbi Yasavoli

Peer review under responsibility of **UCT Journal of Management and Accounting Studies**

Introduction

Edwards believes a high spiritual intelligence with information about different spiritual intelligence. This distinction between practical and theoretical knowledge to raise knowledge stems. It should have an extensive knowledge of spiritual matters and Tmryn-Hay Hm-Rdyf them achieve spiritual intelligence through prayer and meditation to solve moral issues, however, can be said to Bhrh-Mndy affecting spirituality, having both theoretical knowledge and practical respectively. Although much research has been done in the area of development of spiritual intelligence and experimental research is needed, but it can be said that this talent intelligence in different people, different And in a collision with a rich environments on My-Angyzand spiritual questions, and gradually evolved form. It seems that age and gender also influence in spiritual intelligence. Yong believes that in most people after 35 years a major change in the subconscious conducted in spirituality and spiritual intelligence that may affect the process. Speak to achieve the objective of facilitating the introduction is stopped. (Ceske, 2002; Wellman, 2001) spiritual intelligence, adaptive and functional cases in particular Mvqyt-Hay and everyday life. (Nozzle, 2004). This view includes all events and experiences that influence a person is an overall look have been. One can use this intelligence to be Charchvb-Dhy and reinterpret their experiences. This process is able to nomenologically Bh-Rvydadha and give more personal meaning and value of individual experiences (nozzle, 2004). Spiritual intelligence with the inner life of the mind and the soul and its relationship with the world and the capacity of a deep understanding and insight into the question of multiple levels of consciousness occurs. Awareness of the breath, as the context or life force, creative development and on behalf of. Spiritual intelligence appeared in the form of consciousness is an ever growing awareness in the form of matter, life, body, mind, soul and spirit Drmy-Yd. So spiritual intelligence is nothing more than a person's mental ability to Mavra'frd and the spirit of the relevant screw.

Statement of the problem

Today, in modern management concept of quality of work life around the world has become a major social issue. Any improvement in the quality of work life programs organizational culture that promotes the growth and excellence of employees in the organization. Thus, the value of investing in people's life quality as the most important variable Strategic management considers in the equation (Ghaffari, 1388). Study findings suggest that components of these applications reduces the amount of complaining employees, reduce absenteeism rates, reducing the amount of exercise disciplinary regulations, increased positive attitude and increase their participation in military programs were suggestions. On the other hand, meet employees' needs and improve long-term performance will be the result. Today, more empirical research that has been done in terms of quality of life, implied a new vision of job satisfaction and career-related concepts accepted. Although in some Texts quality of work life and job satisfaction are considered as synonymous, but many experts believe that management science and industrial psychology quality of work life and job satisfaction are different in concept.

The difference in quality of work life and job satisfaction in the fact that job satisfaction is a result of the quality of working life. Dana and Griffin believe that the quality of working life as a pyramid that its concepts including life satisfaction [At the top] job satisfaction in the middle of it], as well as satisfaction of other aspects such as the satisfaction of working for the rights, co-workers and supervisors (the Taherid, 1390).

Quality of working life means a process by which all members of the organization through open communication channels and appropriate for this purpose has been created In particular the decisions that their jobs, and their overall impact on the environment to find an intervention and As a result of their participation and satisfaction of their work and work-related stress is reduced. In fact, the quality of working life As a result of their participation and satisfaction of their work and work-related stress is reduced. In fact, the quality of working life Represents a corporate culture or management style is based on its staff a sense of ownership, autonomy, responsibility and self-esteem are. In an organization for creating these feelings in What are your employees there are differences. In general, the program success in an organization that has a reputation for quality of work life, giving and receiving suggestions, questions and criticisms that can be Any improvement in the work lead there willingly. In such an atmosphere, creative dissatisfaction sign of respect and compassion manufacturer nor criticism is devastating for the organization.

According to the above can be Such as that "quality of working life" means the possibility of more satisfying personal needs of employees of security for the people so that they can continue to live safely with others and feel useful and ultimately accept and be accepted by others have opportunities to increase their skills and knowledge (Rudaki, 1389).

Spiritual Intelligence, the intelligence against intellectual intelligence and emotional intelligence that computers take advantage of the high level seen in some mammals, particularly humans. Zohar and Marshall spiritual intelligence to introduce a new dimension of human intelligence, and to consider them and to solve problems and conceptual Hvshnhayy Value is used. Spiritual intelligence field all those things that we believe in them and believe. Serious questions about where we come from, where we are going and what is the main purpose of life, the manifestation of spiritual intelligence, mistakenly.

This intelligence intellectual intelligence and emotional intelligence is essential for effective function. In fact the gateway's rational intelligence to succeed in his favorite discipline, but what she puts her among the best in the profession, emotional intelligence (Asadi, 1390).

Benefit from at least the beginning of the journey towards spirituality, emotional intelligence, spiritual intelligence is self-awareness and emotional intelligence is that it ensures. On the other hand, emotional intelligence can also be effective in the promotion of spiritual intelligence. Two emotional intelligence and spiritual intelligence direct and positive impact on each other. Foster growth and development of each other. Various aspects of consciousness and spiritual intelligence Cindy Vygylvs believes that spiritual intelligence is the ability to behave

with compassion and understanding during internal and external peace, regardless of circumstances and events. While people with intellectual intelligence judgment, the ability to have a fair and compassionate behavior. Our spiritual intelligence Enables you to see things as they are. This intelligence is the same intelligence that has led the world's popular leaders. With this intelligence, spiritual leaders can handle the pressure (Ghaffari, 1388).

Robert Aymvz tried spirituality based on Gardner's definition of intelligence, spiritual intelligence framework pose. He believes that spiritual intelligence collection capability to take advantage of religious and spiritual resources Is. It Aymvz Five able to communicate this intelligence: the physical and material excellence: people with spiritual intelligence, high capacity excellence and desire to have consciousness. To enter the spiritual level of an ultimate reality which creates a feeling of oneness and unity aware Darnd.tvanayy find holiness in Activities, events and everyday relations: recognize the divine presence in normal activities. The ability to utilize spiritual resources to solve the problems of life: People who are religious in nature and easier it will be to deal with stress than others on spiritual crises and overcome problems (Taherid, 1390).

Spiritual intelligence tremendous impact on important variables such as management, leadership, motivation, self-control, the ability to change, communication, and performance, as well as its relation to other types of intelligence causes Spirituality and spiritual intelligence become an important topic in the field of management and organization. Managers who have a spiritual perspective, to change, receptive and looking for purpose and meaning for their organization. The importance of connection to a larger whole You know, perception and individual expression of their spirituality.

They have an abundance mentality believe that there are sufficient resources for all and need not compete. As a result, people will trust each other more easily, Share information and work in partnership with colleagues and members of his group are coordinated to achieve their ultimate goals. Organizations that are in the hierarchy of spiritual orientation, to empower each attempt. Cooperation strategies in conflict situations Win - Win use (Ahmadi Renani, 1391).

Spiritual director in dealing with situations instead of interfering in the affairs, to pay insight, rather than control, and instead bring up your confidence, to show humility. Spiritual director on ethical values such as honesty, integrity, freedom and justice emphasized. He improved staff moral identity and deep commitment In their ruling creates and makes constructive relations between them. Spiritual director on individual development, joint decision-making, and help emphasize self-actualization. If his core values be threatened, the Instead of adapting to the ideas of others, they will be challenged to reach high results. Spiritual director does not allow the position to engage his mind, Instead of adapting to the ideas of others, they will be challenged to reach high results. Spiritual director does not allow the position to engage his mind, Because the mind is always faced with this threat By position and margin seemingly taken hostage Shvd.mdyr important spiritual rather than be guided by Position, a position created and directs. Today psychologists believe that the ultimate success of an organization depends on its great spiritual

intelligence of managers and staff though a rational Intelligence and Intelligence This success is also partly emotional guaranteed. They believe the encouragement of spirituality in the workplace can lead to increased creativity, honesty and trust, a sense of personal development, organizational commitment, job satisfaction, participation Job, morality and work ethic, motivation, performance and productivity is high. A spiritual director will be able to successfully lead their organizations so that all customers, employees and community members to benefit from it (Rudaki, 1389).

So the aim of this study is to answer the question of whether the quality of work life and spiritual intelligence in the Golestan Province welfare organization there is a significant relationship?

Literature:

- Theoretical Pour et al., (1390) in a study to evaluate the effect of spiritual intelligence and organizational justice has been on the quality of working life. The study population are university employees using the Cochran formula Make 59% of the sample of 241 randomly selected sampling have been determined. After gathering information through a standard questionnaire based on a Likert scale of five that its validity and reliability was confirmed by the subjects, After gathering information through a standard questionnaire based on a Likert scale of five that its validity and reliability was confirmed by the subjects, The data were analyzed by structural equation modeling technique and all hypotheses were confirmed at a confidence level of 59 percent.

- Ziaee et al., (1390) in a study of the impact of employee empowerment and spiritual intelligence on Tehran University have measured; Their findings showed that there is a significant relationship between spiritual intelligence and employee empowerment. They also concluded that the components of spiritual intelligence and organizational commitment to improve the quality of working life impact Gzarnd.

- Moqimi, (1390) to investigate the relationship between organizational justice and quality of life have paid employees. It also means that the relationship between organizational justice, distributive justice, procedural justice and interactive justice Quality of work life are examined. The population consisted of all employees in Qom province governmental organizations that are sample includes 264 employees. Data collection tool is a questionnaire. Kolmogorov-Smirnov test data by mean of a population and Friedman test Pearson correlation test using SPSS software were analyzed. Findings positive relationship between organization and quality of work life are revealed. Further analysis showed that these three dimensions of organizational justice dimensions were positively correlated with the quality of work life Darnd.

- Yazdani, (1389) investigate the relationship between spiritual intelligence and QWL in East Azerbaijan province's elementary school teachers. Population consisted of all elementary school teachers in East Azerbaijan province 92-91 students to the number 12136 people have formed. A total of 706 people through Cochran's formula and were selected by multistage cluster sampling.

Hypotheses

- The quality of work life and spiritual intelligence in

theGolestan Province welfare organization there is a significant relationship.

- Between decent work and spiritual intelligence in theGolestan Province welfare organization there is a significant relationship.

- Between individual productivity, well-being and spiritual intelligence in theGolestan Province there is a significant relationship.

- Between organizational productivity and spiritual intelligence in theGolestan Province welfare organization there is a significant relationship.

Research Methodology

Research methodology

The methodology of this research is descriptive and correlational survey. In terms of this study is among the research field. Applied research and scientific problems is an attempt to respond to a problem that exists in the real world (earthy, 1382, 94).

Data collection

Library and field data collection is done in two ways.

The data collection tool

In this study, according to subject matter and methods that survey questionnaire was used as research tools. In this study to evaluate the quality of work life questionnaire Walton (1998) and spiritual intelligence standard questionnaire to measure Ismail Nazareth (1387) It uses.

The method of analyzing information.

Data analysis in this study are the following:

1. Descriptive statistics for evaluation of central and statistical frequency distribution tables will be set.
2. inferential statistics (ANOVA) is used to test the hypothesis. It should be recognized that to generalize the results of the test are usually used. In the present study to analyze the data using structural equation test software. It lisrel.

The population, sample size and sampling

The population in this study includes all employees of the Department of Social Welfare Gonbad city against 57 people in the study sample Bashnd.hjm Welfare Department staff and in theGolestan Province In this study, the sampling and sample of the population census is used as a sample.

Theoretical definitions of variables

Quality of working life:

Quality of working life means a process by which all members of the organization through open communication channels and appropriate for this purpose has been created In particular the decisions that their jobs and their overall impact on the environment to find an intervention and therefore their participation and satisfaction More work and stress of their work is reduced. In fact, the quality of working life represents a corporate culture or management style is based on its staff a sense of ownership, autonomy, responsibility and self-esteem are (Seifi, 1385).

Spiritual Intelligence:

Includes an adaptation and behavior problem solving with the highest levels of growth in adjusted Cognitive, moral, emotional, interpersonal, and so on, and the person in order to achieve the integration Coordinating with internal and external phenomena around him and help My-Nmayd (Abdullah Zadeh, 1386).

Operational definitions of variables

quality of working life:

The mean scores of the respondents to the questionnaire Walton (1998), which represents the quality of working life is the answer.

spiritual intelligence:

The mean scores of the respondents to the questionnaire spiritual intelligence Ismail Nazareth (1387), which represents the spiritual intelligence responds.

Descriptive statistics of variables

According to Table 4-8 Descriptive statistics for all variables in terms of statistical indices shown in the following table.

Jdv14-8-variables descriptive statistics

Variable	symbol	N	Minimum	Maximum	Mean		Std. Deviation	Variance
		Statistic	Statistic	Statistic	Statistic	Std. Error	Statistic	Statistic
Quality of working life	QWL	57	1.67	5.00	4.6632	.02687	.52662	.277
Doeth working	WO	57	1.33	5.00	4.4288	.02986	.58521	.342
Individual productivity	IP	57	2.00	5.00	4.3531	.03702	.72544	.526
Organizational efficiency	OE	57	1.00	5.00	3.3509	.03890	.76224	.581
Spiritual Intelligence	SI	57	1.25	5.00	4.1738	.04582	.89797	.806

For example, for quality of work life (QWL) Comments amount of 1.67 minimum and maximum values of 5.00 and mean comments Comments 4.6632 and 0.52662, respectively, to the Democrats.

For variable decent work (WO) Comments amount of 1.33 minimum and maximum amount of 5.00 and mean comments Comments 4.4288 and 0.58521, respectively, to the Democrats.

For individual productivity variable (IP) Comments amount of 2.00 minimum and maximum values of 5.00 and mean comments Comments 4.3531 and 0.72544, respectively, to the Democrats.

For variable organizational efficiency (OE) Comments amount of 1.00 minimum and maximum amount of 5.00 and mean comments Comments 3.3509 and 0.76224, respectively, to the Democrats.

For Spiritual Intelligence (SI) Comments amount of 1.25 minimum and maximum amount of 5.00 and mean

comments Comments 4.1738 and 0.89797, respectively, to the Democrats.
4-3-3-test hypotheses,

In this part of the test hypotheses using the software Lisrel pay.

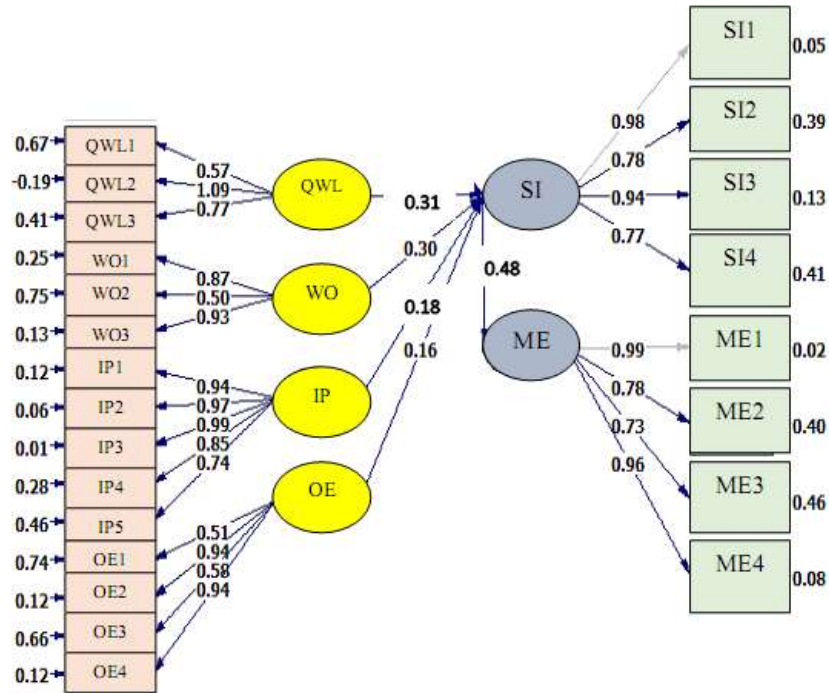

Chi-Square=1013.62, df=344, P-value=0.00000, RMSEA=0.073

Figure 4-1 investigating the structural model in standard mode

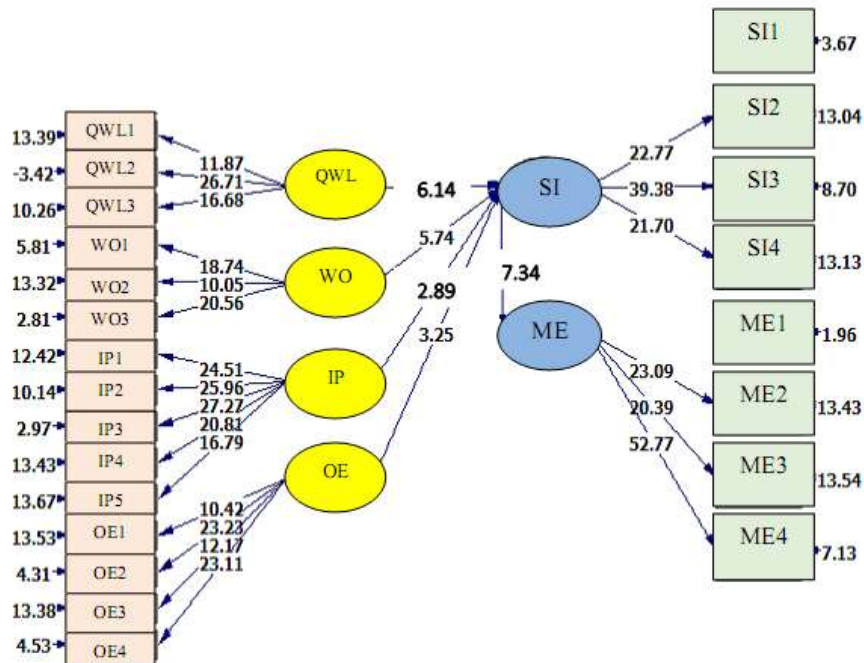

Chi-Square=1013.62, df=344, P-value=0.00000, RMSEA=0.073

Figure 4-2 investigating the case, significant structural model

To estimate the model using maximum likelihood ratio chi-square test to determine the model of two degrees of freedom (χ^2 / df), the comparative fit index (CFI), fit index (GFI), adjusted index Fitness (AGFI), soft indicator of

fitness (NFI), soft index's loose fit (NNFI), root mean square error of approximation (RMSEA) was used.

The results of the research hypotheses:

Hypothesis 1: the quality of work life and spiritual well-being in the Golestan Province there is a significant relationship.

As is clear from Table 4-11, the path coefficient of 0.31 was obtained quality of work life and spiritual intelligence. T for the relationship between 6.14 and higher than the threshold of a significant amount of 96.1 is obtained. According to the above, we can conclude there is a significant relationship between quality of work life and spiritual intelligence. The first hypothesis of this study is confirmed.

Hypothesis 2: Welfare Organization between decent work and spiritual intelligence in the Golestan Province there is a significant relationship.

Model Fitted show route between decent work and spiritual intelligence coefficient is 0.30. Since the value for this ratio, 5.74, and its value is higher than the 96.1 achieved a significant threshold, it can be concluded that the obtained coefficient is significant. In other words, decent work and significant positive correlation with spiritual intelligence. The second hypothesis is an approved research.

Hypothesis 3. Between individual productivity and spiritual intelligence in the Golestan Province welfare organization there is a significant relationship.

According to Table 4-11 can be said coefficient of 0.18 and spiritual intelligence is the relationship between individual productivity. T for the coefficient of 2.89, and a significant amount above the threshold of 1.96 was obtained. So individual productivity has a significant relationship with spiritual intelligence. The research confirmed the assumption placed third.

hypothesis 4. between organizational efficiency and spiritual intelligence in the Golestan Province welfare organization there is a significant relationship.

Model shows the relationship between organizational efficiency coefficient of 0.16 and spiritual intelligence. T for this coefficient is 3.25 and its value significantly higher than the 96.1 threshold is achieved. In other words, organizational efficiency and a significant positive correlation with spiritual intelligence. It placed fourth hypothesis confirmed.

The research proposal
5-4-1 offers from results

Suggestions results of the first hypothesis: the results of the first hypothesis imply endorsement relationship between two variables, the relationship between quality of work life and spiritual intelligence in the Golestan Province significant relationship exists welfare organization. So the quality of work life, spiritual intelligence in the city welfare office Gonbad increases. The authors expressed the importance of quality of work life is evidence that shows employees happy, productive employees who are ADULTS and they are committed and dedicated to the organization. Many researches have shown significant effects on quality of working life reactions Behavioral employees including job performance and productivity as a result of it. In fact, the quality of working life can lead to an increase in welfare centers of spiritual intelligence employees.

Suggestions results of the second hypothesis: the results of the second hypothesis imply endorsement relationship between two variables, the relationship between decent work and spiritual intelligence in the Golestan Province

there Welfare Organization. So to increase decent work, Golestan Province increased level of spiritual intelligence welfare organization. Although the quality of working life such as decent work perspective to cover the range of activities freely used (particular set of theories, philosophies and schools of thought continuous approach to organizational design, problem-solving approach and techniques for improving quality). But in many cases it is an organizational development strategy and A method for operating effectiveness and productivity even technical development managers and employees to improve communication in the organization could be decent work. In fact, spiritual intelligence staff increase their welfare.

Suggestions results of the third hypothesis: the results of the third hypothesis suggests confirming the relationship between two variables, the relationship between individual productivity and spiritual intelligence in the Golestan Province there Welfare Organization. The quality of work life for themselves but also for patients and care personnel provided the effective dimension Affects productivity. Reported higher job satisfaction leads to increased job satisfaction, increased productivity and effectiveness of employees' organizational and spiritual intelligence. In fact, increasing the quality of work life is nothing anti-productivity and performance. By increasing the quality of work life organizational needs and goals met.

Suggestions results of the fourth hypothesis: The fourth hypothesis results imply endorsement relationship between two variables, the relationship between organizational productivity and spiritual intelligence in the Golestan Province there Welfare Organization. So by increasing organizational productivity, level of spiritual intelligence in the city welfare office Gonbad increases. Human services organizations, today a major issue of poor quality of work life. Welfare services managers with increasing expectations for collaborative work environments and more humane, pressure to control costs while increasing the effectiveness and progress of technology that must be faced Treat employees learn and work environment as an interactive learning environment personnel - client build. Since the issues arising from the poor quality of work life of managers. In addition, productivity attention Thus can affect other aspects of corporate welfare organization can To improve the quality of working life by paying attention to the effects on individuals and their organizational effectiveness.

references

- Reza Ardalan, Srchhany Zahra, Srchhany M. (1393). Spiritual intelligence and maturity of the relationship between quality of work life of primary school teachers in the area 2. *New Approaches in Educational Administration*. 5 (1): 81-103.
- Gholami, A. (1388). Factors affecting the quality of work life organization. *Police human development*. 6 (24): 80-100.
- Almasi Hassan, grace Mohammed Zarei Yazdani M. (1390). Quality of work life and employee performance. *Business management*. 2 (9): 69-86.
- Ghaffari, GH and hope, R. (1388), quality of life, social development Development Index, Tehran: Publication headband.

University College of Takestan

Taherid M., K. F., shoemaker, M. (1390). Impact on the quality of work life of employees Raja social capital. 4. Social Research (13): 59-80.

Rudaki, M. (1389), dynamic analysis of the quality of working life, productivity and system management master's thesis, Islamic Azad University, South Tehran.

Ahmadi Renani, Z. (1391), check the quality of working life of staff in Tehran, Iran Insurance Company, Thesis (MA), University of Education and Psychology Bhshty.danshkdh martyr.

Asadi, Mohammad Hossein (1390), management efficiency and improve the quality of jobs, the newspaper of democracy, No. 1890.