



The relationship between strategic human resource management on employee development and organizational learning mediator role in the melat of bank branches in Golestan Province

Khadijeh Tahmasbi Yasavoli

Department of Management and Accounting, Aliabad katoul Branch, Islamic Azad University, Aliabad Katoul, Iran

Original Article:

Received 01 March, 2017 Accepted 1 June, 2017 Published 7 July, 2017

ABSTRACT

The aim of this study was to investigate the relationship between strategic management of human resources, employee development and organizational learning mediator role in Melat Bank branches in Golestan province. The research methodology was descriptive, correlational research is survey. The target population included all employees of Bank Melat Province Golestan 600 people. The sample proportional to the number of people using Morgan table, 234 individuals were randomly selected sampling. The data were collected by library and field methods and tools used standard questionnaires. The reliability of the questionnaire using Cronbach and validity have been confirmed by the content. In order to analyze the data, structural equation modeling using LISREL software is used. The results show the strategic management of human resources, employee development and organizational learning mediator role in Melat Bank branches in Golestan province there is a significant relationship.

Keyword:

strategic human resource management, employee development, organizational learning

*** Corresponding author Khadijeh Tahmasbi Yasavoli**

Peer review under responsibility of **UCT Journal of Management and Accounting Studies**

Introduction

Given the dramatic changes in social and organizational environments intensifying competition in the world today more than ever, organizations are looking to attract and More importantly, maintain and develop current and future processes of their people. Organizations are looking for new capital as human capital, to say that human capital is a factor more than any other single factor affects the growth and survival. The importance of human capital in all fields expanded, so that modern growth theory to human capital accumulation attention And even human capital as an influential factor in the economic development of communities as human. given that the topic is novel in human resources. A strategic issue for organizations is increasing in organizations and societies. In short, human capital plays an important role in the prosperity of the people, improve living standards and income, increasing knowledge and skills, production capacities, economic growth and Reduce poverty. Due to recent developments, future research in the field of human capital has two objectives are, first, to assess gaps in human capital pays off.(Asadi,2012).

Second, how human capital productivity and income leads more. Due to the fact that employees and human capital into employment environment They also receive business promotion. The results and findings to the family and the state of the logic that a large sector investment Of its resources on education and manpower training are the most important and rarest source. Given the importance of human resources in organizations in this study was to investigate the relationship between strategic management of human resources, employee development and organizational learning mediator role in Melat Bank branches in Golestan province were considered.

Statement of the problem

Since human resources are the most valuable and important asset of any organization and production and the main source of competitive advantage birth Causing fundamental competencies of each organization, one of the major organizational planning, human resource planning. An important factor for the existence of human resources planning, planning to meet the needs of skills, education and improvement of human resources is the end. The most effective way to achieve a competitive advantage in today's organizations more efficient by improving and upgrading their staff And what is important in the development of human resources is to improve human resources with technical and professional training can not be obtained We will have multiple ways to pay staff development and strategic management of this important part of the realm of human resource management will be possible. One of the most important and the core activities in an organization to keep pace with changes and competitiveness positive healthy The use of systems improvement and innovation in human resources in order to achieve the desired goals and is the manufacturer of the organization. In a sense, you could say: "Our era is an era of change and man today has undergone waves of change, the world has turned into a raging ocean waves boat crew changes every moment that we call the world. To throw this hand, and in any modern human life is not so much changing. ... "(Robert, 2013: 36).

The most important factors for economic and social development of the important and constructive role at different times due to effective human resources Unlike other human beings as creative and efficient role Which can promote the qualitative and quantitative aspects of their work and new methods to overcome the potential problems. Trained and skilled manpower can be granted with the power of your thinking and make the best use of available resources (Sadler&Mert,2009).

The fact is that if organizations are creative people, knowledge workers, opportunity recognition and explanation of issues of interest, many will lose opportunities and situations. To achieve the goal of globalization, or even stay at this level, in order to continue growing and replaced the new way of development and progress is required, and the future belongs to those for which the program and purpose. Since human resources are considered strategic resource for organizations, important and integral part of most discussions of strategic planning and organizational planning and human resources are of strategic nature. The main factors that lead to new approaches in the strategic planning of human resources and process changes Technological change, social and economic internal and external environments of organizations are constantly faced with. If organizations want these changes should be in line with the comprehensive and strategic approach and consider the various requirements. At present, the major source of competitive, efficient human resources or The knowledge workers themselves. However, many organizations lack the expertise and skills are needed to be able to effectively provide human resource strategic plans. The important point is that human resource strategies necessary for the formation of partnerships and co-director of human resources with senior management of the organization. Align and link Strategies and cooperation in various fields of human resource managers, senior management, human resource development creates The planning of human resources development consisting of two components:

Strategic human resource management, human resource management is based on the important role that the strategic nature resources Human and organizational strategy focuses on integrated human resources strategy. Schuler (2011) Strategic Human Resource Management describes as "all activities that influence people's behavior in inciting them to design and implement the strategic needs of the organization." schuler and Jackson (2011) Strategic Human Resource Management The planned allocation of human resources and activities they want to help the organization achieve its goals. Strategic Human Resource Management, a way to make decisions about the objectives and plans of the issues, such as: employment, recruitment, training, compensation and performance management are related. In fact, strategic human resource management generally describes the relationship between human resource management and strategic management organization (Armstrong, 2010) .vjh difference between traditional concepts of human resource management and strategic human resources management, from the standpoint of August (1987) the management integration human resource processes. Strategic decisions in order to deal with

environmental changes. Hollenbeck et al (2001) believes that the competitive environment, the market and technology globalization and continuous change, the main reasons for the change in concepts of human resource management into the strategic management of human resources. Traditional concepts of human resource management only Physical skills, special education, special skills and performance of individual employees and insisted instead pay attention to people, to things that were done by the people, was the focus. While strategic management of human resources, in addition to the above, in all sectors, the overall effectiveness and integrity of the organization's activities, emphasizes (Armstrong, 2001).

The main goal of strategic human resource management, creating macro perspective, the possibility of addressing the underlying issues of staff provided. Strategic human resource management would benefit organizations of skilled staff, committed and motivated in their efforts to achieve sustainable competitive advantage is its purpose, a sense of purpose and Loaded Being in today's turbulent environment, often so that the business needs of the organization and the individual needs and Some employees of the design and implementation of coherent policies and action programs and human resources to be provided. Organizations with high levels of organizational learning, the continuous ability to create results that they really It is desirable increase. Organizational learning makes new mental models and develop extensive and regular people learn how to learn together. Organizations with such characteristics due to encouraging innovation, knowledge, capability development, signs of environmental, interpret and apply opportunities They.lmkrd any person in any situation is indicative of insight that person to that particular situation or issue in which the assessed Since people with organizational learning, knowledge and information indicative of Individuals with regard to the factors affecting the organization.

Therefore, organizational learning can be one of the factors affecting organizational health of individuals within the organization. vang and cheng (2010) believe that strategic human resource management framework should be a single, wide, contingency, and seamlessly create A. HRM strategy to create maximum coordination and cooperation between employees and the organization. With increasing complexity, the team can better work. Now a growing number of companies have turned to the use of autonomous work groups, research shows that using groups Work improves quality and efficiency. Due to increasing attention to strategic human resource management tries to examine the relationship between organizational learning and staff development.

The main research question is whether the strategic management of human resources, employee development and role Organizational learning mediator in melat Bank branches in Golestan province there is a significant relationship?

Hypotheses

- The strategic management of human resources, employee development and organizational learning mediator role in Melat Bank branches in Golestan province there is a significant relationship.

- The strategic management of human resources and staff development branch of the Melat Bank of Golestan province there is a significant relationship.

- Between strategic human resource management, organizational learning there is a significant relationship Golestan Melat Bank branches.

- Human resource management strategies with organizational learning there is a significant relationship Golestan Melat Bank branches.

- The role and position of human resources and organizational learning there is a significant relationship Golestan Melat Bank branches.

- The internal human resources strategy with organizational learning there is a significant relationship Golestan Melat Bank branches.

- External human resources strategies with organizational learning there is a significant relationship Golestan Melat Bank branches.

- Between organizational learning and staff development branch of the Melat Bank of Golestan province there is a significant relationship.

Research methodology

The methodology of this research is descriptive and correlational survey. In terms of monitoring and control of field research among the research. Applied research and scientific problems is an attempt to respond to a problem that exists in the real world (Earth, 1382: 94).

Data collection

Library and field data collection is done in two ways.

The data collection tool

In this study, according to subject matter and methods as the survey questionnaire The survey instrument used. In this study, a standard questionnaire was used to measure variables. Strategic Human Resource Management standard questionnaire to assess strategic human resource management (Armstrong, 1998), to measure organizational learning questionnaire Organizational learning (Jolia, 2001) and standard questionnaire to measure staff development personnel development (Robbins, 2000) was used.

The population sample size and sampling

The population of the research staff at Melat Bank branches in Golestan province, which is an important loss of 600.

The study sample consisted of 234 employees of the Melat Bank of Golestan Province using the table Morgan and stratified random sampling method was obtained. It should be noted that given that there was a possibility of the return of the questionnaires The sample size was added at a rate of 10 percent and a total of 260 questionnaires were distributed.

History Research

- Mohammad (1393), in a study entitled The relationship between strategic management of human resources on staff development Mediating Role of Organizational Learning in bank branches nation's Gilan province. The research method was descriptive and the goal is to find the relationship between strategic management of human resources, employee development and organizational learning mediator role. For data analysis, descriptive and inferential statistics methods using LISREL software is done.

The results showed that the strategic management of human resources, employee development and organizational learning there is a significant mediating role.

- Hosseini (1393), in a study entitled impact of HRM practices on Organizational learning capability. The research method was descriptive and the goal is to find the relationship between HRM practices has been on learning ability. For data analysis, descriptive and inferential statistical methods using SPSS software have been performed. The results showed that HRM practices on organizational learning capabilities have a significant relationship.

- Eyvazzadeh and Moin (1392) study the effect of human resources on the development of East Tehran's Islamic Azad University staff. This study examines and analyzes the role of human resources in East Tehran's Islamic Azad University staff development. The aim of this The main indicators of organizational management study that includes five subscales; Force the issue staff, recruiting and employee selection, design and implementation of training programs, evaluation of staff performance and the performance of teachers on courses in organizational units. For this purpose, the statistical community managers and employees Islamic Azad University, Tehran East 90 individuals were selected using simple random sampling. In order to analyze the data from the statistical model for each of the questions related to the management of one-sample T Human resources were used, as well as using the T-test to compare the amount of each item with an emphasis on corporate official (employee director) has been And concluded that the effect on the development of human resources management-level employees alpha is effective 0/01 percent.

- Azmi (2011) in a study entitled The relationship between strategic human resource management, human resource management effectiveness and functioning of public institutions in India focused. The study uses a descriptive, correlational survey. Data library and field study. And tools used standard questionnaires were collected. The reliability of the questionnaire using Cronbach and validity have been confirmed by the content. The Pearson correlation test to analyze the data using software is used lisrel. The results show that among all Components, strategic human resource

management, human resource management effectiveness and functioning of public institutions in India there is a significant relationship.

- Vylmant (2010) examined the relationship between human resource management and organizational learning objective of this study was to investigate the relationship between human resource management and organizational learning at the radio station in Latvia. For data analysis, descriptive and inferential statistical methods using SPSS software have been performed. The sample consisted of 37 people. The results showed that there is a significant relationship between human resource management and organizational learning.

- Joe Lia (2012) in a study entitled Evaluation of relationship between the functions of strategic management of human resources and technical innovation. In this study, 480 faculty members Hodder Punjab stratified random sampling method in this study have been. In order to collect the data, the functions of strategic management of human resources and technical innovation questionnaire was used. Data analysis showed that the mean scores Strategic Management Human resources and technological innovation at the University of scores less than average and the functions of strategic management of human resources with technical innovation there are significant multiple correlation. Comments on the relation between the strategic management of human resources with technical innovation based on demographic characteristics significant difference existed.

The theoretical framework

The aim of this study was to investigate the relationship between strategic management of human resources, employee development and organizational learning in Melat Bank branches in Golestan province is the role of mediator. To this end strategic human resources management According to Armstrong (1998) and development of staff. According to Robbins (2000) as well as organizational learning Nyfh (2001) also considered, which is also based hypotheses are formed .

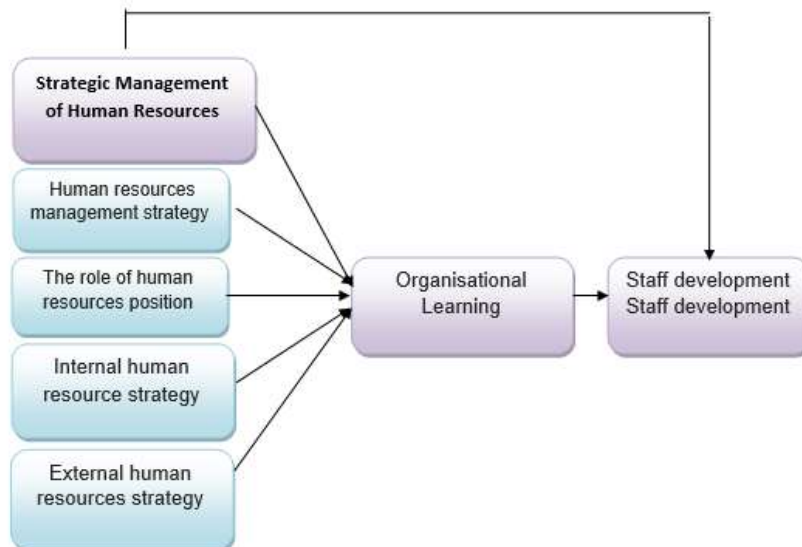

Figure 1-1 conceptual model (Azmi, 2011).

Analysis information.

Data analysis in this study are the following:

1. Descriptive statistics to estimate and adjust the central features of statistical frequency distribution tables are used.

2. inferential statistics used to test the hypothesis. It should be recognized that to generalize the results of the test are usually used. In the present study to analyze the data with the help of software tests LISREL structural equation is used.

Test hypotheses,

In this part of the test hypotheses using the software Lisrel pay.

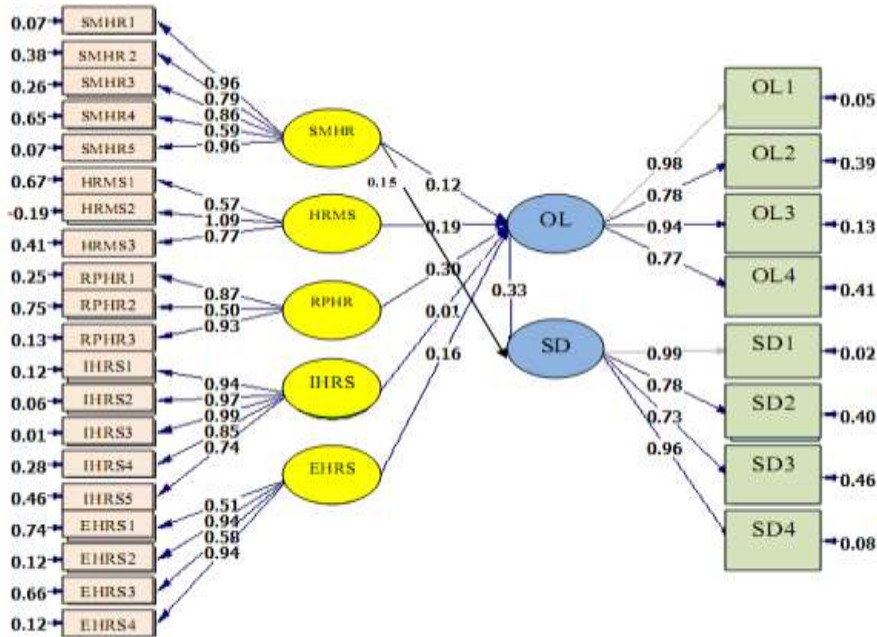

Chi-Square=1013.62, df=344, P-value=0.00000, RMSEA=0.073

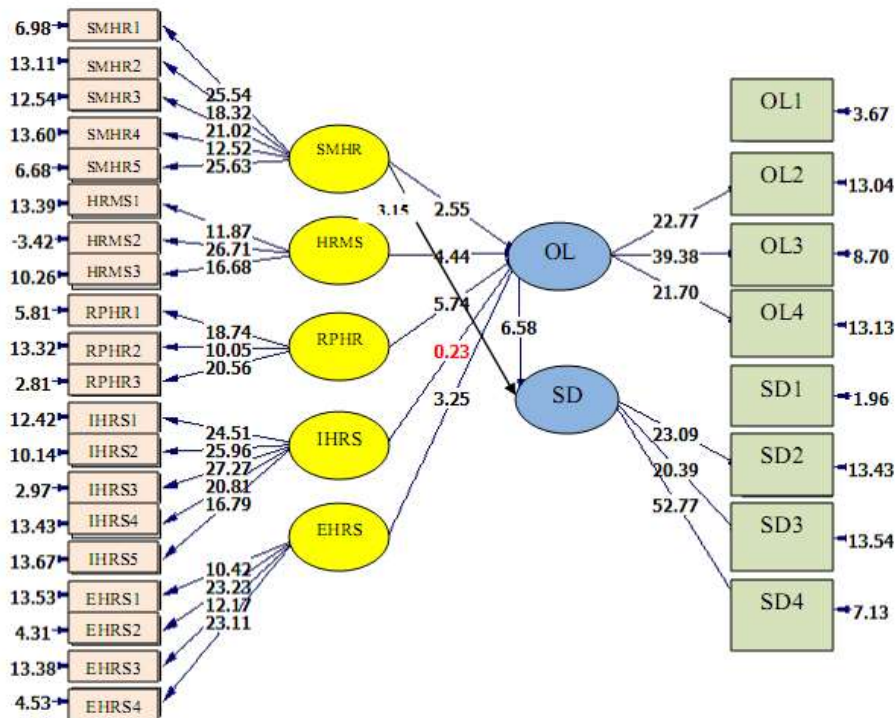

Chi-Square=1013.62, df=344, P-value=0.00000, RMSEA=0.073

The result is a significant direct relationship and assumptions of the model coefficients

Test result	meaningful	Path coefficient	sign	Direction
Acceptable	3.15	0.15	SMHR---SD	Strategic Human Resource Management ----- staff development
Acceptable	2.55	0.12	SMHR --- OL	Strategic Human Resource Management --- organizational learning
Acceptable	4.44	0.19	HRMS --- OL	Human Resource Management strategy --- organizational learning
Acceptable	5.74	0.30	RPHR --- OL	The role and position of human resources and-- - organizational learning
Acceptable	0.23	0.01	IHRS --- OL	Internal human resource strategy --- organizational learning
Acceptable	3.25	0.16	EHRS --- OL	External strategy, human resources and--- organizational learning
Acceptable	6.58	0.33	OL --- SD	Organizational learning and--- staff development

Conclusions and Recommendations The results:

A: H1. Between strategic human resource management, staff development branch of the Melat Bank of Golestan province there is a significant relationship.

According to the table index can say the relationship between strategic human resource management, staff development 0.15. T for this coefficient is 3.15 and its value is also higher than the 1.96 achieved a significant threshold. Based on the above it can be concluded strategic human resource management and development of employees' There meaningful. The first hypothesis of this study was to verify the screw.

B: H2. Between strategic human resource management, organizational learning there is a significant relationship Golestan Melat Bank branches. According to Table 4-12 can be said of the relationship between strategic human resource management and organizational learning path coefficient is 0.12. T for the coefficient of 2.55 is also higher than the threshold of significant amounts of 1.96 is obtained. Based on the above it can be concluded strategic human resource management, organizational learning and positive relationship exists meaningful. The second hypothesis of this study was to verify the screw.

C: Hypothesis 3: Human resource management strategies with organizational learning there is a significant relationship Golestan Melat Bank branches. As is clear from Table 4-12, the path coefficient of 0.19 was obtained HRM strategy with organizational learning. T higher than the threshold value is significant for the relationship 4.44 and the 1.96 is obtained. Based on the above it can be concluded HRM strategy with organizational learning is meaningful. The third hypothesis of this study was to verify the screw.

D: H4. The role and position of human resources with organizational learning There is a significant relationship Golestan Melat Bank branch staff. Fitted model shows the value of the role and position of human resources with organizational learning is 0.30. Since the value for this ratio, 5.74 and its value significantly higher than the 1.96 threshold is obtained, it can be concluded that significant coefficients were obtained

respectively. In other words, the role and position of human resources with organizational learning has a positive relationship meaningful. The research confirmed the hypothesis placed fourth.

E: H5. Internal human resource strategy with organizational learning there is a significant relationship Golestan Melat Bank branches.

According to Table 4-11 can be said that the relationship between the internal strategy of human resources with organizational learning path coefficient is 0.01. T for this coefficient is 0.23, and its value is significantly lower than the 1.96 threshold is achieved. So internal human resources strategies with organizational learning is not meaningful. The fifth hypothesis It is not confirmed by the investigation. And: H6. External human resources strategy with organizational learning there is a significant relationship Golestan Melat Bank branches. Fitted model shows the external value of the relationship between human resources strategies with organizational learning 0.16. T for this coefficient is 3.25 and its value is higher than the 1.96 achieved a significant threshold. In other words, external strategy, human resources and a significant positive correlation with organizational learning. The study also confirmed the assumption placed sixth.

G: H7. Between organizational learning and staff development branch of the Melat Bank of Golestan province there is a significant relationship. Fitted model shows the relationship between organizational learning and staff development coefficient is 0.33. T for this coefficient is 6.58 and its value significantly higher than the 1.96 threshold is achieved. In other words, organizational learning has a positive and significant relationship with staff development. The study also confirmed the assumption placed seventh.

H: Hypothesis 8. Strategic Human Resource Management on the role of mediator between employee development and organizational learning in Melat Bank branches in Golestan province there is a significant relationship. Fitted model shows the path coefficient between strategic human resource management and organizational learning and the value for this coefficient of 0.12, 2.55, and its value is significantly higher screw threshold of 1.96 is obtained.

The path coefficient and t value obtained for the relationship between organizational learning, staff development, respectively, 0.33 and 6.58 respectively. So it can be concluded between strategic human resource management and development of staff through organizational learning, a positive and significant relationship.

Recommendations for future research

In addition to their research questions have answers, provide grounds for any questions newer. In this section refers to items that can be the basis of researches in the field of research:

- ◆ - model for strategic management of human resources in the branches of the bank in Golestan province.
- ◆ - application of strategic human resource management and organizational learning in melat bank branches in Golestan Province.
- ◆ - evaluate the impact of strategic human resource management and development of staff in bank branches in Golestan province melat s.
- ◆ - provide a model for improving the strategic management of human resources and staff development in melat bank branches in Golestan province.

References

- Asadi, D. (2012), 'Human Resource Management and Industrial Relations,' Journal of Management Studies, 24, 5, 503–521.
- Roberts, Gary E. and Pavlak, T. (2013). **Municipal government Personnwl Professional and Performance appraisal: Is there a consensus on the characteristics of an effective appraisal system?** Public Personnel Management, Vol. 25. No. 3, Fall
- sadler.S and Mert.I.S (2009), **Impact of the strategic human resource management on organizational performance: evidence from Turkey.** The Intermelat Journal of Human Resource Management. Vol. 22, No. 8, April 2011, 1803–1822,
- Armstrong, Michael, (1989) **A Handbook of Human Resource Management Practice**, Kogan Page.
- Ackoff Russell I.(1999)."on learning and the systems that facilitate it",
- Adair, J.(2002).**Effective strategic leadership"** London.MacMillan publishing.and Knowledge Creation",StrategicManagement Journal, 20, 637-653.Zack, M.
- sholeri, N. (2008), '**Managing Human Resource for Competitive Advantage: A Study of Companies in Singapore,**' Intermelat Journal of Human Resource Management, 11, 2, 336–365.
- Schuler, R.S., and Jackson, S.E. (2011), '**Linking Competitive Strategies with Human Resource Management Practices,**' Academy of Management Executive, 1, 3, 207–219.
- Snell, S. A & Bohlander, G. W. (2007). **Managing Human Resources. Thomson Publishing Company.**
- Stredwick, John (2005) **An Introduction to Human Resource Management. Elsevier Ltd.**
- UO, R.A, Hollenbeck, J. R, Gerhurt, B & Wright, P.M. (2001). **Human Resource Management: gaining Competitive advantage.** New York: Mc GrawHill.
- vang, B.E., and cheng, M.A. (2010), '**High Performance Work Systems and Firm Performance.**

- Jolia, C. (2009), '**Strategic HRM: Enablers and Constraints in the NHS,**' The Intermelat Journal of Public Sector Management, 16, 1, 48–60.