



The relationship between the use of ICT with organizational health and employee empowerment mediator branches of Melli Bank of Golestan province

Aynaz Farkhondeh¹ and Roohallah Samiee^{2*}

1 Department of Management, Ali Abad katoul Branch, Islamic Azad University, Ali Abad Katoul, Iran

2 Department of Management, Ali Abad katoul Branch, Islamic Azad University, Ali Abad Katoul, Iran

Corresponding Author: Roohalla.samiee@gmail.com

Original Article:

Received 10 July. 2016 Accepted 10 Aug. 2016 Published 30 Sep. 2016

ABSTRACT

The aim of this study was to investigate the relationship between information technology and communication with the organizational health role of mediator empowerment Melli Bank branches in Golestan province. The research methodology was descriptive, correlational research is survey. The target population included all employees of the Melli Bank of Golestan province is 700 people. The sample proportional to the number of people using Morgan table 248 and stratified random sampling method was selected. The data were collected by library and field methods and tools used standard questionnaires. The reliability of the questionnaire using Cronbach and validity have been confirmed by the content. In order to analyze the data, structural equation modeling using LISREL software is used. The results show that the organizational health role of mediator between the ICT empowerment branches of Melli Bank of Golestan province there is a significant relationship.

Keyword:

ICT, empowerment, organizational health

* Corresponding author: *Samiee*

Peer review under responsibility of UCT Journal of Management and Accounting Studies

Introduction

and knowledge in different parts of the world and of distance learning network coverage and become far different from traditional methods and conventional methods, training. In the e-learning system, lifelong learning, there is no space and time limits for each person (Akoczy, P(2014)). ICT or as some virtual education in the simplest definition of the educational process on the electronic communication platform. Although e-learning educational technologies with the involvement of interaction between Fraym and teachers has changed, still believed that e-learning in the beginning. Unlike traditional e-learning process is centered on learning and educational content. For students under the supervision of instructors who should participate in the development of educational content. E-learning, science is taken to places where previously there was record of training (Dillon and Morris, 2010).

In today's competitive world, it is undoubtedly one of the most important tools in the creation and evolution and survival of the organization and achieve the desired goals, programs and modern teaching approaches; in the meantime, what gives life to the issue of evolution and survival of the organization ensures the human element and human resource development.

Today, education as one of the ways forward is the development of human resources. Every organization needs people trained and experienced to carry out their mission. Education skilled technical people who will be remembered as the development of human resources, is inevitable that organizations survive and thrive in today's world hard work and need for transformation; Many scholars Management and Economics believe that among the types of investments that in order to improve efficiency, and ultimately to economic and social development takes place, empowerment of human resources as effectively contributing element in the realization efforts, the most significant and most profitable pillar of development Are. Training and development of human resources in the current era to certain conditions, one of the tasks is inevitable, organizations and institutions; this is primarily in the form of short-term or long-term training programs carried out. A training program can not be considered a cost-effective, unless a comprehensive evaluation done it. Training managers not only need to learn to be responsive staff, but also to make this knowledge and skills to lead empowering employees be held accountable.

Statement of research problem

The world development in electronic teaching system makes more learning opportunities and accessibility of educational and scientific resources, so far as this matter primarily wasn't realized in traditional methods and markets. By using electronic teaching system in education and the other hand, teaching based electronic system, can not only accelerate and facilitate services and staff efficiency growth in organization but also makes many innovations and evolutions in educational methods (Revile J 2010). So it cannot deny that intranet and extranet, free libraries and conversational abilities and link technology and hypertext and Meta data Models can play on important roll. These methods are strong and confident substructures, which support education process and therefore, the cooperation

between systems and staff, educational space and human communication, are cloned. (Akoczy P2009). Intranet means the organizational internal network by which can observe organization data. Actually intranet is a private network. Some organizations and institutions even banks permit individuals and other organizations, especially staff to use intranet. The special intranet that can operate users out of organization or bank, were called extranet. In this reason that in bank Melli substations is necessary to investigate the application modern electronic system and the conditions which was produced by these methods. It should note that, although by computer sites in informatics part of bank and also performance some educational classes and the implement this education by bank intranet and also the learning educations in out of bank by extranet, is constructed a convenient pattern in bank melli substations to use staff intranet, but it should assemble convenient applications to these methods were executive better and better making the growth efficiency between staff. And also by this method is assessed which one of available electronic methods more can influence in education and also the efficiency personnel. In the recent decade, organization efforts by knowledge innovation schools increase scientific level and creativity of their staff by loss of temporal and local restriction, this method can situate presence educations. The participation in online educational classes and concurrent accessibility to internet, presents usage of extreme scientific statue for scholars. The commercial companies require daily information and fast decision makings in hard fluctuations of market to get innovation and can protect themselves in competition field. Despite of ability to grave accessibility, commercial companies propend to use electronic teaching.

The relation between electronic system and teaching and efficiency personnel is a necessary and bilateral one. Thus if there aren't the labor which know methods, literature, computer and its applicable proficiencies, it cannot hope development real efficiency and melli permanency knowledge based. Furthermore electronic system is an effective method for education and efficiency growth labor. (Duvalier R 2012) In general as ideology, the long – short term efficiency depends on education and culture. Hence the education can be considered an important instrument in quality rate and development. The educational system increases the efficiency personnel. This is possible when education planning and engagement are entirely coordinated and utilized teaching growth level and schooling records (documents). According to japan efficiency center, this corresponds with education, theory and conceptual sight of efficient human. This definition is represented fallowing: the purpose of efficiency is scientifically the great usage of resources, labor, facilities, and so on, and or reduction of production costs, extension goods, increscent jobs, effort for increscent of real wages and improvement life standards, so that personnel, managers and customers all benefit them. Hence people that he/she can accomplish better his/her affairs towards agone and therewith he/she endeavors. The relationship that definitely instructs us: the better teaching is equal to more efficiency. Never less its constancy, teaching in class and online education isn't able to comprise entirely these tasks. The "electronic learning" posits above

"electronic teaching". The measure of growth process, knowledge change and increasing constriction in banks compel new methods to achieve completion teaching. (Training) It is impolitic terminate responsibility of learning. In any place and temporal, for learning in work place, the space that has a civilized electronic system requires instruments equipped with new electronic system. (Rosenberg, 2010) Today some of soft wares have an outspread nature and educational program is one of them. The personnel service systems are drawn simultaneity on network in service systems, so that they can use it. In the educational outspread system are able any staff utilize another experiments when they are going to train special purpose. (Wails J, Bandi 2009) the electronic teaching includes the great list of applications and operations, such as web based teaching, computer based teaching, virtually classes and electronic cooperation (Azadi, 2013). Also the teaching that is considered by internet and intranet is called virtually teaching and the its place is called a place of electronic collage. In this place are established classes, libraries, management affairs and consultative counter relationships made in network. (Fahimi,2008). The daily change in hard and software technology, universalized, over plus expectations of client, competitive construction, technology staff in organization, unnecessary of individuals educational classes, the necessity of organization for efficiency growth staff by modern electronic teaching system justified with other great banks. (Kenneth CL, Janne PL 2009). The electronic teaching is an argument in which accurses many changes and innovations. Forasmuch as this field relates with dynamic sciences, then it can revolve and innovate. Naturally the innovation doesn't belong to merely to hardware (equipment and tools) but it can be observed in many parts of software (methods, technique and patterns). So that the definition of this field changes once per several years. Klerk and Mayer introduce electronic teaching as fallowing: this is a teaching that is represented by compact plate global internet local network. In a lecture exhibited Allen Wagner his research findings about electronic teaching projects, in this conference, he offered a chart that indicates ascent, apex and downfall process of innovation and electronic innovation. Rajerz (2008) believe that innovation in society is adopted gradually by interests and then if innovation is useful, the rate of adoption increases.

The education can correlate more with efficiency, whatever education is more specialized. It seems that whatever education is scientifically, searchingly and technology (electronic teaching) more specialized and professional and technical, will be able relate more with efficiency. The main question in this research is: Is the use of ICT with organizational health and employee empowerment mediator branches of Melli Bank of Golestan province there is a significant relationship?

History Research

Zwass, Valdimi (2011) were considered the research called: the study of usage electronic teaching on staff efficiency improvement in Islamic Azad University. The research manner was cross - sectional and the kind of research was experimental and the kind of purpose was applicable. In this research, the statistical universe consists of all Andimesk university staff, their number was 86 persons, and they are selected as statistical sample. The test of research theories were used questionnaire as research

instrument. Its stability Is earned 89% By using of Kronbach α factor. The consequences show that there is a meaningful relationship between electronic teaching and efficiency improvement.

Smith M. Jorj, N. Davidson, Z (2014) investigated the research called the relationship between knowledge and organizational innovation in an assurance company. Through 180 experts in Assurance Company, coincidental 86 persons were selected as exemplar group. The information that belong to variant knowledge management utilizes vig model used by "Numan" and " Sedra and Gabel" and the information that considers variant organizational innovation is produced by " Moghimi" and " Shahhoseyni and Kavooosi" model. The results of Espirman correlation factor show that knowledge indices, knowledge preservation, knowledge conduction, and knowledge application have a meaningful relationship with innovation. Maximum correlation factor about calculation of organizational innovation concerns to the variant knowledge application, that is 0/878 factor, and its minimum related to knowledge preservation, that is 0/656 factor. For organizational innovation, the managers require in different parts integration knowledge capitals and knowledge of external and external labor. Beside, the knowledge should be performed across of organization to enhance organizational innovation.

Kumar, V., Smart, P. A., Maddern, H., Maull, R. S. (2008). has considered a research named: the study of relationship between knowledge management and organizational innovation in Kerman melli organizations. In this study is surveyed the relationship between knowledge management and organizational innovation in Kerman melli organizations. In this research, statistical universe is 1035 personnel in organizations using kokran formulate for sample volume and by cluster – incidental sampling are selected 280 persons. The information about variant knowledge management is used by Numan, Sedra, Gebel based vige model and the information about variant organizational innovation is earned by Moghmi, Shahhoseyni and Kavooosi model. The results of Espirman correlation factor show that knowledge incides knowledge preservation, knowledge conduction and knowledge application have a meaningful relationship with innovation. For organizational innovation require the managers integration knowledge capitals in different parts and knowledge of external and internal labor. Beside, the knowledge should be performed across of organization, so the possibility appearance organizational innovation will enhance.

Michel (Mike) Rober (2015) has considered a research named: the study of relationship between multiplex knowledge and innovation in financial services organizations in bank Refah kargaran. The purpose of this study is evaluation of relationship between multiplex knowledge and innovation. The fore utilizes multiplex knowledge methods based Dikson model and the latter also utilizes trade – labour hegemony evolution model measuring innovation by questionnaire among 96 bank Refah kargaran staff and its results show that in 95% certainty level , there is a meaningful and positive relationship between multiplex knowledge and innovation. Moreover there are similar results between apparent (clear) multiplex knowledge variants, hidden multiplex knowledge, strategic multiplex

knowledge, specialized multiplex knowledge with innovation. Finally are offered the research restriction and practical purpose.

Research Methodology

The study of the nature and objectives of the research are applied. Applied research and scientific problems is an attempt to respond to a problem that exists in the real world (Earth, 1382: 94). As well as the method of data collection is descriptive.

Data collection

Library and field data collection is done in two ways.

The data collection tool

In this study, according to the survey questionnaire investigated the matter and the methodology to be used as a research tool. In this study, a standard questionnaire was used to measure the research variables. Heavy GHQ questionnaire to assess organizational health and Feldman (1989), a standardized questionnaire to assess information

and communication technology (Jinhua, 2000) and to assess the empowerment of Spritzer questionnaire (2001) was used.

The method of analyzing information.

Data analysis in this study are the following:

1. Descriptive statistics for evaluation of central and statistical frequency distribution table is set.
2. In order to test the research hypotheses, structural equation modeling software is used lisrel.

The population and sample size

The population in this study all branches of Melli Bank of Golestan province, which has 700 employees, respectively. Since the probability of return to the questionnaires was 20% higher then the questionnaires were distributed to the 298 number.

Test hypotheses:

In this part of the test hypotheses using the software Lisrel pay.

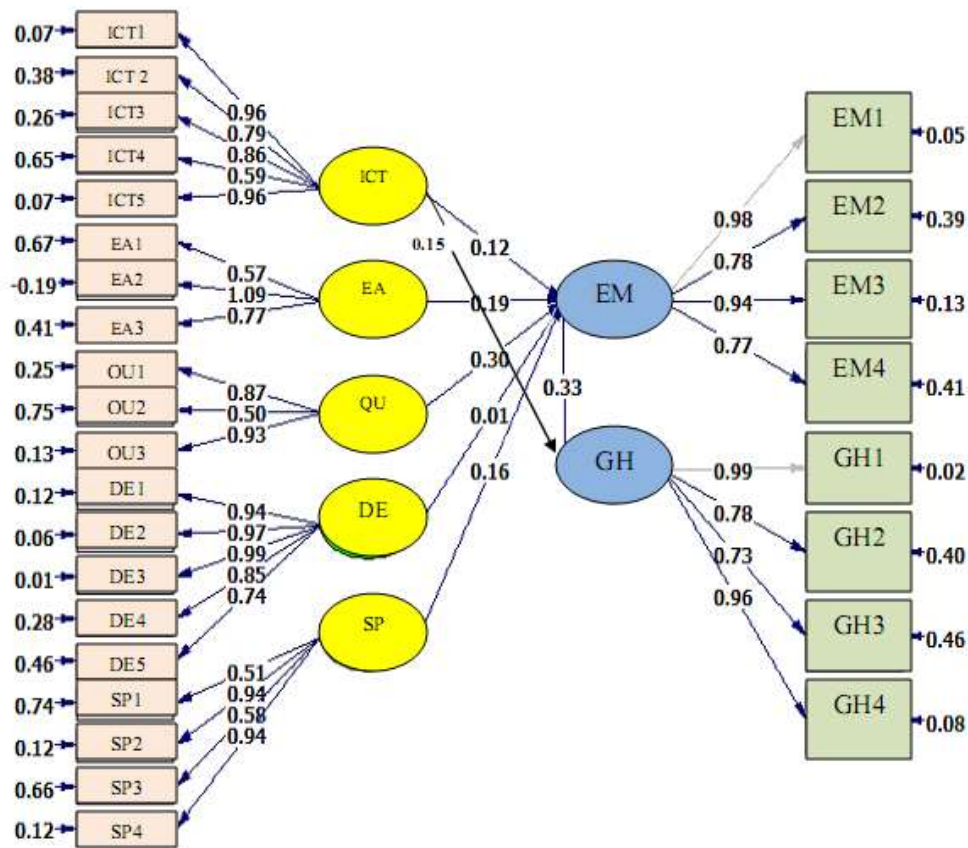

Chi-Square=1013.62, df=344, P-value=0.00000, RMSEA=0.073

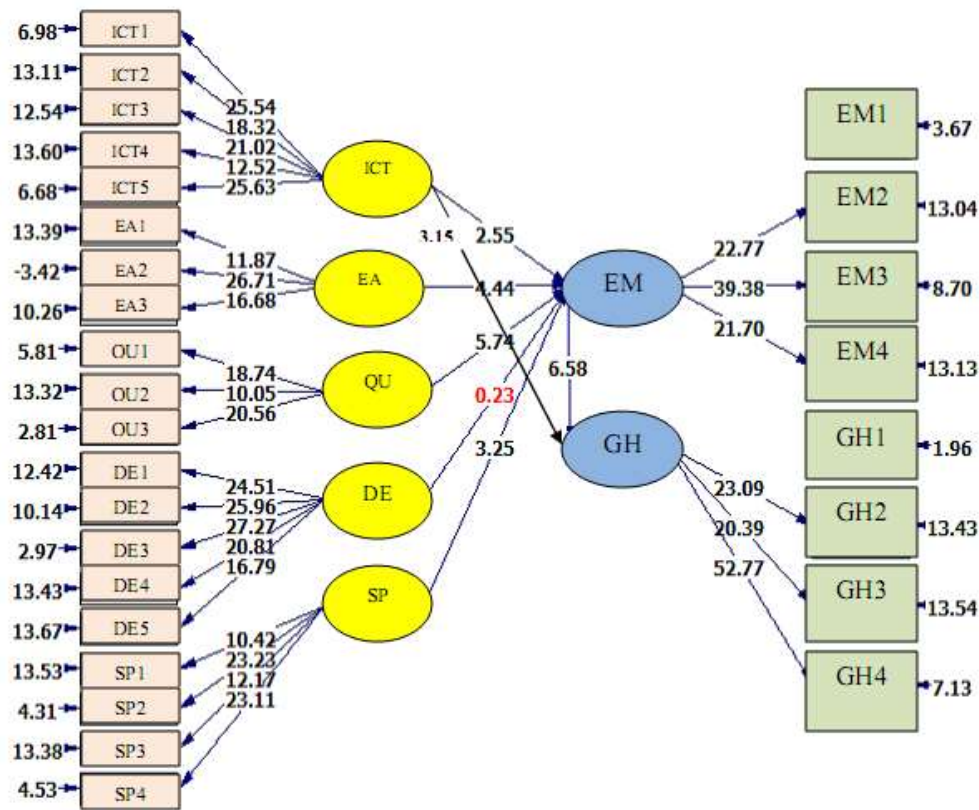

Chi-Square=1013.62, df=344, P-value=0.00000, RMSEA=0.073

Direct and significant correlation coefficients model assumptions Results

Test result	meaningful	Path coefficient	sign	Direction
Acceptable	3.15	0.15	ICT---GH	ICT---GH
Acceptable	2.55	0.12	ICT---EM	ICT---EM
Acceptable	4.44	0.19	EA---EM	EA---EM
Acceptable	5.74	0.30	QU---EM	QU---EM
Not Acceptable	0.23	0.01	DE---EM	DE---EM
Acceptable	3.25	0.16	SP---EM	SP---EM
Acceptable	6.58	0.33	CBT ---SQ	CBT ---SQ

The results of the research hypotheses:

H1. Between ICT and organizational health branch of the Melli Bank of Golestan province there is a significant relationship.

According to Table can be said of the relationship between ICT and organizational health path coefficient of 0.15. T for this coefficient is 3.15 and its value is also significantly higher than the 1.96 threshold is achieved. Based on the above it can be concluded ICT and there is a significant positive relationship with organizational health. The first hypothesis of this study is confirmed.

H2. Between ICT with empowerment branches of Melli Bank of Golestan province there is a significant relationship. According to Table can be said of the relationship between ICT empowerment path coefficient is 0.12. T for this coefficient is 2.55 and its value is also higher than the 1.96 achieved a significant threshold. Based on the above it can be concluded ICT empowerment There is a significant

positive relationship. The second hypothesis of this study is confirmed.

H3: between access to information and communication technology with empowerment branches of Melli Bank of Golestan province there is a significant relationship.

As is clear from Table the path coefficient of 0.19 Easy access to ICT empowerment is achieved. T for the amount above the threshold of a significant relationship between 4.44 and 1.96 is obtained. Based on the above it can be concluded easy access to ICT has a significant relationship with empowerment. The third hypothesis of this study confirm the result.

H4. The quality of information and communication technology with empowerment branches of Melli Bank of Golestan province there is a significant relationship.

Fitted model suggests that some factor in the quality of the ICT empowerment is 0.30. Since the value for this ratio, 5.74, and its value is higher than the 1.96 achieved a significant threshold, it can be concluded that significant coefficients are obtained. In other words, the quality of

information and communication technology has a significant and positive relationship with empowerment. The fourth research hypothesis is confirmed.

H5. The demand for ICT with empowerment branches of Melli Bank of Golestan province there is a significant relationship.

According to the index table can be said that the relationship between the demand for ICT empowerment is 0.01. T for this coefficient is 0.23, and its value is significantly lower than the 1.96 threshold has been achieved. So the demand for ICT Mna-Dary no relation to empowerment. The fifth research hypothesis can not be confirmed.

H6. Between stability and efficiency of enterprise IT and communication with empowerment branches of Melli Bank of Golestan province there is a significant relationship.

Model shows the value of the relationship between stability and efficiency of information and communication technologies to empower 0.16. T for this coefficient is 3.25 and its value is higher than the threshold of significance of 1.96 was obtained. In other words, sustainability and efficiency of ICT empowerment has a significant positive relationship. The study also confirmed the assumption placed sixth.

H7. Between empowerment and organizational health branch of the Melli Bank of Golestan province there is a significant relationship.

Model shows the value of the relationship between organizational health empowerment is 0.33. T for this coefficient is 6.58 and its value is higher than the threshold of significance of 1.96 was obtained. In other words, empowerment, positive and significant relationship with organizational health. The seventh research hypothesis is confirmed.

H8. ICT has the role of mediator between organizational health and employee empowerment branches of Melli Bank of Golestan province there is a significant relationship.

Model shows the path coefficient between ICT and empowerment and the value for this coefficient of 0.12, 2.55, and its value is significantly higher than the 1.96 threshold is achieved. The path coefficient and t value obtained for the relationship between empowerment and organizational health are respectively 0.33 and 6.58. So it can be concluded between the mediating role of ICT with organizational health and employee empowerment, positive and significant relationship.

References

- Akoczy, P(2014). **Information technology and introduction**. 1st rev. ed. London: Pitman;. 1 – 50 p.
- Amir Azadi A(2013). **21st Centry Universities and Effective far education**. 1st melli virtual University Seminar. Kashan: Kashan University2013. (In Persian)
- Dillon and Morris (2011), “ **Determinants of radical product innovations** ”,*European Journal of Innovation Management* Vol.9, No.1, pp.20-43
- Burt, R.S. (2014). "**Interpretational Confounding of Unobserved Variables in Structural Equation Models**", *Sociological Methods and Research*.
- colly comber R'(2014) **Operations research for libraries and information** ' *Journal of Government In formation* - Volume 29 ' - September - October

- Duvalier R. **100% online student success**. 1st rev. ed. New York: Delmar Cengage Learning, 2012. 1 – 30 p.

- Deyvis , C vera, D. (1989) strategic Leadership and organizational learning *Academy of management Review*. 29, pp:222-240.

- Fahimi M. **Informational Technology in the education and development**. *Payame Ketabkhan magazine*. 2008; 133: P 21. (In Persian).

-Gallagher, D., Ting, L., Palmer, A. (2014). "**A Journey into the Unknown: Taking the Fear out of Structural Equation Modeling with AMOS for the First-Timer User**", *The Marketing Review*255-275.

-Hair, J.F., Black, W.C., Babin, B.J., Anderson, R.E., Tatham, R. (2015)."**Multivariate Analysis (6th ed.)**", New Jersey: Pearson Education Inc.

- Kenneth CL, Janne PL. **Management information system – organization and technology**. **Mohseni H, translator**. 1st rev. ed. Tehran: Ketebdar Publication; 2009. (In Persian).

-Kumar, V., Smart, P. A., Maddern, H., Maull, R. S. (2008). "**Alternative Perspectives on Service Quality and Customer Satisfaction**",*The Role of BPM*. Intermelli *Journal of Service Industry Management*.

Michel(Mike)Rober(2015)**t,Product Innovation Strategy Pure and Simple**, McGraw – Hill.

.McLeod , Rozanberg,(2014) , **Management in formation systems' Seventh ed** ' Newjersy ' prentise Hall.

- Rosenberg M J. **Beyond E – Learning**. 1st rev. ed. San Francisco: Pfeiffer (an imprint of Wiley); 2014. 1 – 20 p.

- Revile J. **Techniques and strategic procedures of management information systems**. **Berenji M R, translator**: Kamale Tarbiyat Publication; 2010. (In Persian).

Smith M. Jorj,N.Davidson,Z(2014) **Informational Technology in the education and development**. 1st rev. ed. New York: Delmar Cengage Learning,1 – 15 p.

Wails J, Bandi J. **Supervising in management, training guide and better doing the educational and studing programs in 2015**. Berenji M R, translator. Tehran: Kamale Tarbyat Publication; 2009. 405 – 420 p.

.Zwass, Valdimi (2011)'R' **Management Information System** , WM,C ,Brown