



## RFID as an enabler of maintenance management

Alireza Veiseh<sup>1</sup> and Jalal Haghghat monfared<sup>2</sup>

*1Department of IT Management, Electronic Branch, Islamic Azad University, Tehran, Iran  
arveiseh@gmail.com*

*2Department of Industrial Management, Central Tehran Branch, Islamic Azad University, Tehran, Iran  
J\_haghghat@iauctb.ac.ir*

### ABSTRACT

Efficiently, tracking information related to components, materials and equipment from the production/construction phase to operations and maintenance is a challenge in the industries. Advanced electronic identification and data storage technologies e.g. radio frequency identification (RFID), are used to identify equipment automatically and to integrate related information with equipment in various industries. The aim of this paper is to present an overview of the state-of-the-art RFID technology in asset and maintenance management. In this research, author has looked into different studies and identified some clear advantages of RFID. maintenance managers can use RFID solutions in order to accurately track movable assets, reducing manual processes through automated scanning and data entry lead to improve productivity, eliminating the costly errors associated with manual inventory, including missed or mis-categorized assets. This technology can potentially reduce the time for handling data in process of maintenance management. Timely and relevant information enables informed decision-making and offers improvement for productivity, safety and security.

### Original Article:

*Received 15 June. 2015*

*Accepted 28 Aug. 2015*

*Published 30 Sep. 2015*

### Keywords:

*radio frequency identification, state-of-the-art, maintenance management*

### INTRODUCTION

Information technology (IT) has been the economic gain, cost saving and quality improvements that serve as the main drivers in pushing for innovative technologies. There are the same relevant drivers for the radio frequency identification (RFID) technology as well. RFID is a powerful data capturing technology that provides electronic identification, tracking, and storing of information contained on tags attached to or embedded in items, such as products, equipment, cases, or pallets. As the global business rapidly changes, organizations seek to continuously improve products and services while lowering the costs. RFID is a technology whose adoption in business environments has been significant growth in recent years. It provides an automated, continuous monitoring solution to a process that has traditionally relied on manual, less frequent observations. Relevant applications of RFID technology can be found in a variety of fields, such as supply chain management, logistics, production, asset and operation management. The technology is highly traceable and has relatively low labor cost (Cox, et al. 2012). In the era when timely information, accurate forecasting of supplies and demands, real-time inventory management, control of warehouses and retail stores are vital for success, the RFID technology yields significant potential for every sector of economy, business and industry such as transportation and cargo, storage and retail, health care, manufacturers, and

any other sectors and domains (Wamba and Berjis, 2010). The use of RFID can extend beyond the needs of assets management. Engineers are afforded the ability to reference and update a part's maintenance history more quickly and easily, facilitating accurate configuration control and repairs reducing warranty claim processing costs. Benefits even extend to accurate and efficient spare parts pooling and easier identification of rogue parts. The ability to accurately track movable assets eliminates the frustration of having to physically locate them and helps avoid unnecessary "just-in-time" purchases when "missing" assets are assumed disposed of. By placing RFID tags on the assets and readers at key entry and exit points and various other locations, movable assets will be automatically tracked and located in real time (Conneely, 2009). Technologies, methodologies, and tools aimed for maintenance are continuously being developed, and improved. As the tools and technologies become more advanced, the need for information process solutions, which can communicate between different systems, such as operation systems and maintenance systems is increasing (Karim, 2009).

#### 1. RFID technology

RFID is a new wireless communication technology that works like a barcode. But without a line of sight. In addition to not requiring line of sight, distinct from barcode, RFID tags could be active and interact with the readers. The two main elements of RFID systems are the devices used to carry this information and the equipment used to

automatically capture or retrieve the information. The devices that store and carry the information are called transponders or tags. The device that is used to capture and transfer information is commonly called a reader or interrogator, because in earlier RFID systems they were only able to read the information sent by the transponders. Interrogators have vastly different complexity levels depending on the type of transponders they support as well

as their specific purpose. Both transponder and interrogator need to use the appropriate antennas to transfer information. In addition to the transponders, the interrogators, and their antennas, as is shown in figure 1, the RFID system requires a host computer connected to the interrogator. This host computer provides a certain level of intelligence and acts like the interface between the RFID system and the ultimate application.

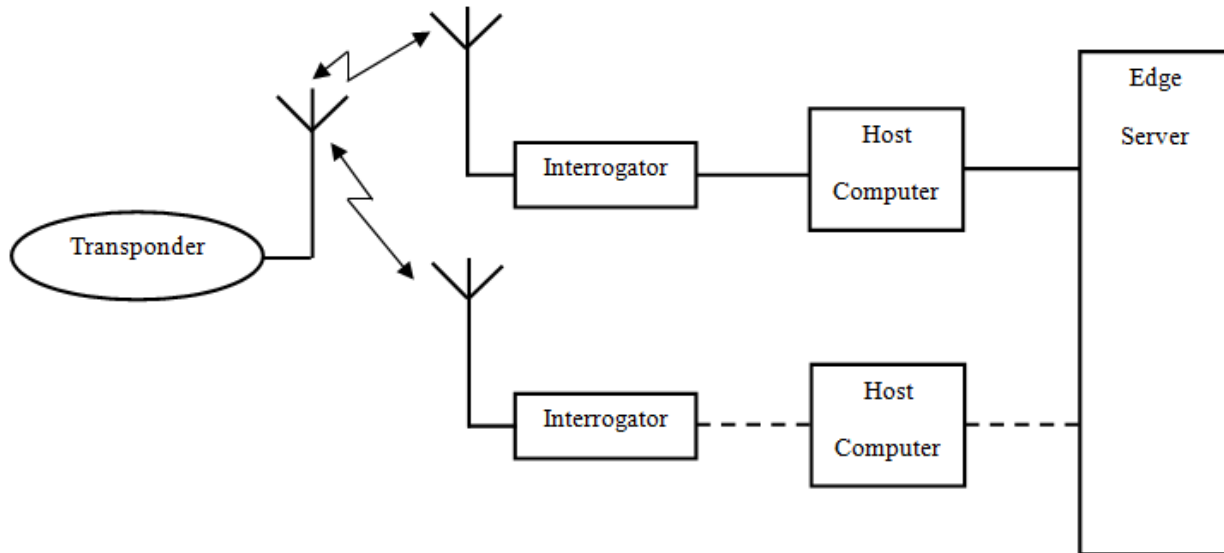

**Figure1.** Basic structure of an RFID system (Nieto, 2011)

Both transponder and interrogator need to use the appropriate antennas to transfer information. In addition to the transponders, the interrogators, and their antennas, the RFID system requires a host computer connected to the interrogator. This host computer provides a certain level of intelligence and acts like the interface between the RFID system and the ultimate application (Lozano-Nieto, 2011). Radio Frequency identification is a fairly young identification method that is becoming increasingly prevalent as the price of technology decreases. It has the

flexibility which allows it to be widely used in a range of applications such as shopping, library, passport identification, fleet management, parking management, e-ticketing, asset tracking, warehouse management and inventory management. In RFID systems, data transmission between tags and readers or sometimes even data transmission between readers and back-end database uses the wireless channel. Therefore, we have to select an adequate frequency dependent on our objective in the project. In table 1 common frequencies of RFID technology are shown.

**Table1.** Commonly used frequency band for RFID systems (Nieto, 2011)

Frequency Band	Frequency Range	Typical Frequencies Used in RFID Systems
Low Frequency (LF)	100 KHz – 500 KHz	125 KHz 134.2 kHz
High Frequency (HF)	10 MHz – 15 MHz	13.56 MHz
Ultra High Frequency (UHF)	400 MHz – 950 MHz	866 MHz Europe 915 MHz United States
Microwaves (μW)	2.4 GHz – 6.8 GHz	2.45 GHz 3.0 GHz

**Passive versus Active RFID systems**

Passive RFID systems are those systems that use passive transponders. Passive transponders do not have an internal power source. They harvest the energy needed by their circuits from the electromagnetic field generated by the interrogator. For this reason, they have a short range, limited to a few feet and often, more realistically, to a few inches. Active RFID systems, on the other hand, use active transponders. Active transponders have an internal power source, typically a battery that allows broadcasting the signal to the interrogator. Because of not being limited to the power harvested by the antenna, they have an extended

read range, typically several hundred feet. A third type of transponder is called semi passive or battery assisted transponder. These transponders also include a battery, but contrary to active transponders, the battery is not used to generate the power to transmit the signal to the interrogator. Instead, the battery is used to support secondary functions like the data logging from different type of sensors. These transponders also harvest the energy from the electromagnetic field generated by interrogator to power its internal circuits other than the sensing and data-logging parts (Adolfo-Nieto, 2011). In table 2 some differences between active and passive tags are shown.

**Table2.** Active and Passive RFID Comparison (CISCO, 2015)

	Active RFID	Passive RFID
Tag Power Source	Internal to tag	Energy transferred from the reader via RF
Tag Battery	Yes	No
Availability of Tag power	Continuous	Only within field of reader
Required Signal Strength from Reader to Tag	Very Low	Very High (must power the tag)
Available Signal Strength from Tag to Reader	High	Very Low
Communication Range	Long range (100m or more)	Short or very short range (3m or less)
Sensor Capability	Ability to continuously monitor and record sensor input, data/time stamp for sensor events	Ability to read and transfer sensor values only when tag is powered by reader; no data/time stamp
Data Storage	Large read/write data storage (128KB) with sophisticated data search and access capabilities available	Small read/write data storage (e.g. 128 bytes)

**2.2. The Characteristics of RFID technology**

Radio Frequency Identification (RFID), one member in the family of Automatic Identification and Data Capture (AIDC) technologies, used to describe a system that transmits the identity of an object or people wirelessly without physical contact by radio waves (Alexan tech, 2015). Not requiring a line of sight and interactivity make RFID a new revolution in retail, replenishment of shelves, warehouse management, inventory control, supply chain management, and particularly any domain where management and monitoring of moving objects are involved (Barjis and Wamba, 2010).

RFID can assist decision makers by providing valuable, real-time information. Barjis and Wamba, (2010) resulted from their research that the use of RFID can significantly transform the current practice of conducting business, improve efficiency of operation and management, and support decision-making process. Brewer et al. and Finkenxeller and Waddington identified characteristics of RFID "Real-time control, Continuous or intermittent tracking Real-time control, Operations in a harsh environment, Hands-free operation, Identification at a distance, Quality control, System and Data security, Flexibility, Downsize and Diversification, The repetition uses, Penetrate, and Read/Write" (Lin and Ku, 2009). Ramudin et al. (2008) investigated the use of an RFID-based control system as it applies to maintenance, repair and overhaul activities in an aircraft engine manufacturing

company and suggest that organizations should take advantage of the full potential of the technology. The use of RFID as part of an organization's infrastructure has the potential benefits of allowing for more effective and efficient decision making using real time data, performing routine and manual task better while reducing cost or possibly even reducing the need for those tasks, and allowing top management better visibility of operational transactions (Kim et al., 2010). Some benefits of RFID are listed below (Zare Mehrjerdi, 2011):

- Automation – reducing manual processes through automated scanning and data entry improves productivity, allowing resources to be reallocated to higher value activities.
- Integrity – improving the integrity of real-time SC information with increased authentication and security and tracking capabilities reducing errors, shrinkage, and counterfeiting while improving customer satisfaction – information is only valuable if it is correct.
- Velocity – reducing workflow issues by minimizing the time spent finding and tracking needed assets, in turn increasing product flow and handling speeds.
- Insight – providing the real-time information needed to make faster, better, and more informed

decisions and the ability to be more responsive to the customer.

- Capability – providing new applications and quality to meet SC partner demands and enhance customer experiences.

**2.3. RFID technological advancement and development**

RFID is the result of the technological advancement and development. This dimension focuses on technological advancement and development associated with RFID. The development of RFID technology involves hardware and software concepts such as RFID system architecture, data communication and networking, software and hardware, prototyping, project life cycle, testing and evaluation. Some of the important technologies in the development of RFID include: RFID tag, antenna, radio frequencies and wave reader, acoustic RF tags, active database, antenna design, collision warning systems, database architectures, digital controller, etc. The design and development of an RFID system requires careful planning taking into account where the technology will be helpful and beneficial, the type of access control, Advanced Encryption Standard (AES), agent-based control, data collection, data management, data security, and performance evaluation. The integration issues of RFID with other IT/IS plays a significant role in the success of RFID implementation and its applications (Irani et al., 2010). Recent advances in RFID technologies have led to greater location accuracy, a more robust infrastructure and application hooks to leverage existing tools within an enterprise ( Calio, et al. 2011).

**3. Maintenance Management**

There are performance measures for quality, production, process, and even financial departments. However, one function within organization that is beginning to emerge as a key to future competitiveness is the maintenance function. The focus of the maintenance function is to insure that all

company assets meet and continue to meet the design function of the asset. What is Maintenance Management (sometimes referred to as Asset Management) and of what importance is it for managers in corporations today? Maintenance (Asset) Management can be defined as “the management of all assets owned by a company, based on maximizing the return on investment in the asset.” This definition encompasses the philosophies contained in many of the more popular techniques currently being utilized by company today (Wireman, 2007).

**3.1. Maintenance Management Process**

What is the process? the course of action and the series of stages or steps to follow in order to manage maintenance properly.

A generic process for maintenance management, integrating ideas found in the literature for built and in-use assets, could consist of the following sequential management steps (Marquez, 2008):

- Asset maintenance planning
  - Identify the asset;
  - Prioritize the asset according to maintenance strategy;
  - Identify its performance requirements according to strategy;
  - Evaluate the asset's current performance;
  - Plan for its maintenance;
- Scheduling maintenance operation
- Manage maintenance actions execution (including data gathering and processing)
- Assess maintenance
- Ensure continuous improvement
- Consider the possibility of equipment re-design

Asset management is a fundamental business process. It determines corporate value and has a direct impact on profitability. The maintenance management model from marquez (2007) is depicted in figure 2.

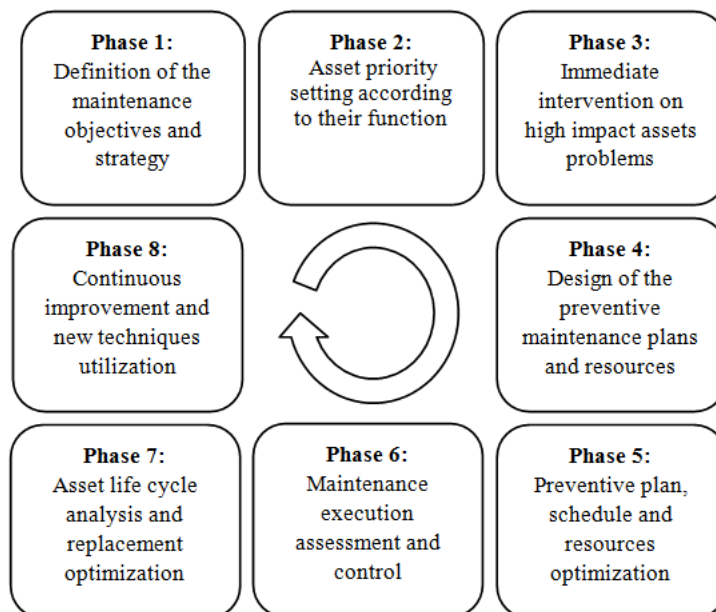
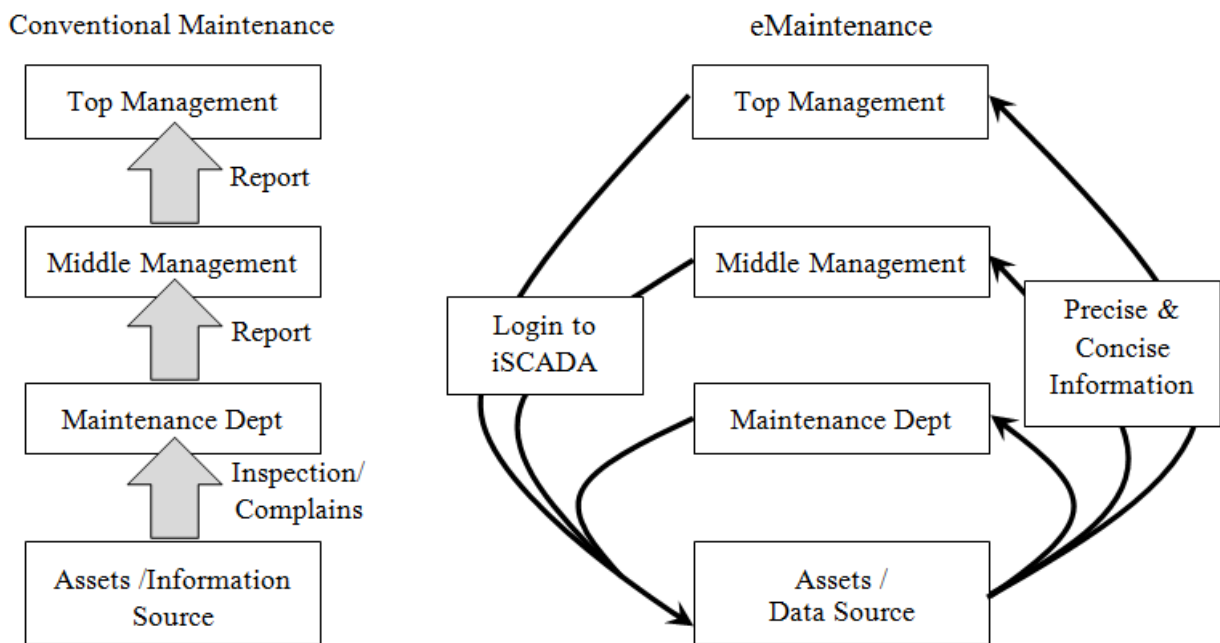

Figure2. Maintenance management model (Marquez, 2007)

**3.3. Maintenance and E-maintenance**

Maintenance is important for the well being of all industries. Computerized maintenance management system (CMMS) provide services to assist the whole maintenance process, e.g. maintenance management, maintenance support planning, maintenance execution, maintenance assessment, and maintenance improvement (Kullolli, 2008). While, supporting maintenance personnel in developing work orders, registering on-going tasks, getting instructions for maintenance tasks, registering completed tasks, reporting deviations/problems, etc. This information is necessary for improving the maintenance process. Technologies, methodologies, and tools aimed for maintenance are continuously being developed and improved (Trettan and Karim, 2014). From a general perspective e-Maintenance concerns the use of new information communication

technologies (ICT) solutions in the field of maintenance (Levrat et al., 2008). Today, ICT-based maintenance solutions, i.e. e-Maintenance are designed to support enterprises with effective and efficient decision-making by enabling just-in-time access to maintenance information (Karim et al., 2009; Wandt et al., 2012). These e-Maintenance solutions (Figure 3) are aimed to support maintenance stakeholders with information solutions adapted to their specific context (Karim, 2009; Candell et al., 2011). E-Maintenance solution with context-sensing capabilities facilitate the interaction between the system and its users, which in turn will contribute to effectiveness and efficiency in the maintenance process. Hence, the provision of the right information to the right user with the right quality and in the right time is essential (Dey and Abowd, 2000; Lee et al., 2006; Parida and Kumar, 2004).



**Figure3. Implementing eMaintenance (Devicesworld, 2015)**

**4. RFID technology and maintenance management**

Companies across a broad spectrum of industries rely on critical assets to drive their business. Manufacturing companies rely on equipment availability and uptime to keep production lines moving and meet production goals. And while the asset types across industries may be varied, there is still a common need for effective management. Any item that is a part of the work process but does not leave as part of a finished product is a candidate for intelligent asset management with RFID. This technology can help enterprises automatically track and secure these assets with very little human intervention. This real-time technology takes asset management to the next level, providing unprecedented visibility, accuracy and security. With RFID, companies can automatically keep track of key assets as they move in and out of an area. With clear visibility into asset status and location, companies are more likely to perform regular and necessary maintenance. With clear visibility into asset status and location, companies are more likely to perform regular and necessary maintenance And

RFID’s automation eliminates the costly errors associated with manual inventory, including missed or mis-categorized assets. The result is an up-to-date accurate picture of asset status as frequently as needed to best manage the business (Lottis, 2002). The on-board data storage capacity of some RFID technologies allow for data storage on a tag attached to a component and enable direct data access from the object. On-board memory can also be integrated with sensors for automatic recording of environmental conditions to a tag (Karygiannis et al., 2007).

RFID technology can potentially reduce the time for handling data in process of maintenance management. It is possible to improve data quality and richness due to the automated identification equipment. RFID allows to obtain a huge amount of information regarding equipment usage and moves inside the project environments (Lopez, et al, 2010).

Assets are often not managed individually information about location, status and usage is often inaccurate or lacking. This may cause delays in industrial operations, insufficient



use or excess inventory of costly assets, and even lead to asset damage or lost.

Timely and relevant information enables informed decision-making and offers improvement for productivity, safety and security. Effective asset management has always been crucial to business success. The goal of asset management is to make assets available when needed and ensure their efficient use. Moreover, many organizations benefited greatly from mobile asset management system (MAMS). These include:

- Elimination of paperwork
- More accurate information on assets
- On-the-spot input
- Transparency

MAMS allows operators to access critical business information such as materials used, asset history, and so on via the mobile devices wherever they performed their asset management task (Chuan Jun, 2009).

Chen et al. (2008) propose a novel system for asset management in enterprises using RFID, web GIS, and SMS technologies. The main merits of the RFID-based asset management systems (RAMS) are as follows. The proposed method can maintains the whole life-cycle of assets from their acquisition, transfer, maintenance, retirement, audit taking by integrating RFID technology.

## 5. Conclusions

Industrial plants and facilities have specific challenges today and they are presented with significant improvement opportunities by the modern communication and identification technologies, which can facilitate and improve to meet these challenges. The general tendency in most industrial sectors is to optimize operation and maintenance processes. In this paper we reviewed literature and researches to explore the benefits of RFID technology as one of the novel wireless communication and identification technology in assets and maintenance management. RFID can help enterprises automatically track and secure these assets with very little human intervention. This real-time technology takes asset management to the next level, providing unprecedented visibility, accuracy and security. Also With clear visibility into equipment status and location, companies are more likely to perform regular and necessary maintenance.

With its tremendous benefits as are explored in this article, this author agrees with other researchers (Emmanouilidis et al., 2009; Chen et al., 2012; Irani et al., 2010; Conneely, 2009 ) that RFID will fit most industries in the coming future.

## References

1. Meng, S., Chiu, D.K.W., Wenyin, L. and Chen, X., 2008. *Automated Management of Assets based on RFID*. s.l., IEEE.
2. Barjis, J. and Wamba, S.F., 2010. Organizational and business impacts of RFID technology. *Business Process Management Journal*, 16(6), pp. 897 - 903.
3. Chattopadhyay, A., Prabhu, B.S., Gadh, R., 2011. *Web based RFID Asset Management Solution*. s.l., IEEE.
4. Chen, K.M., Chen, J.C. and Coax, R.A., 2012. Real time facility performance monitoring. *Assembly Automation*, 32(2), p. 185–196.
5. CISCO, 2015. *CISCO*. [Online] Available at: <http://www.cisco.com/c/en/us/td/docs/solutions/Enterprise/Mobility/WiFiLBS-DG/wifich6.html> [Accessed 5 10 2015].
6. Conneely, K., 2009. Managing corporate assets with RFID. *Assembly Automation*, 29(2), pp. 112 - 114.
7. Crespo Marquez, A., 2007. *The Maintenance Management Framework : models and methods for complex systems maintenance..* London: Springer.
8. Deviceworld, 2015. *Deviceworld*. [Online] Available at: [http://www.devicesworld.net/iscada\\_applications\\_maintenance.html](http://www.devicesworld.net/iscada_applications_maintenance.html) [Accessed 8 September 2015].
9. Emmanouilidis, C., Liyanage, J.P. and Jantunen, E., 2009. Mobile solutions for engineering asset and maintenance management. *Journal of Quality in Maintenance Engineering*, 15(1), pp. 92-105.
10. Ergen, E. and Guven, G., 2013. Factors affecting the selection of data storage approach in radio frequency identification applications. *Construction Innovation*, 13(1), pp. 117-138.
11. Irani, Z., Gunasekaran, A. and Dwivedi, y.k., 2010. Radio frequency identification (RFID): research trends and framework. *International Journal of Production Research*, 48(9), p. 2485–2511.
12. Juels, A., 2006. RFID Security and Privacy: A Research Survey. *IEEE JOURNAL ON SELECTED AREAS IN COMMUNICATIONS*, 24(2).
13. Jun, C., 2009. *Effective Mobile Assets Management System Using RFID and ERP Technology*. Taoyuan, IEEE.
14. Kulkarni, G., Sutar, R., Mohite, S., 2014. *RFID Security Issues & Challenges*. s.l., IEEE.
15. Li, S., Godon, D. and Visich, J.K., 2010. An exploratory study of RFID implementation in the supply chain. *Management Research Review*, 33(10), pp. 1005-1015.
16. Lottis, J., 2007. *RFID Asset Management Solutions*, USA: MOTOROLA.
17. Lozano-Nieto, A., 2011. *RFID design fundamentals and applications*. New York: CRC Press Taylor & Francis Group.
18. Ranky, P., 2006. An introduction to radio frequency identification (RFID) methods and solutions. *Assembly Automation*, 26(1), p. 28–33.
19. Shafeek, H., 2014. Continuous improvement of maintenance process for the cement industry. *Journal of Quality in Maintenance Engineering*, 20(4), pp. 333 - 376.
20. Tanaka, M., Takahashi, N., Ikeda, R. and Suzuki, M., 2012. *RFID Based Maintenance Management System for Ground Coils of*. s.l., IEEE.
21. Tretten, P. and Karim, R., 2014. Enhancing the usability of maintenance data management systems. *Journal of Quality in Maintenance Engineering*, 20(3), pp. 290 - 303.
22. Wireman, T., 2005. *Developing Performance Indicators for Managing Maintenance*. 2 ed. New York: Industrial Press.

23. Zare Mehrjerdi, Y., 2008. RFID-enabled systems: a brief review. *Assembly Automation*, 28(3), pp. 235 - 245.
24. Zare Mehrjerdi, Y., 2011. RFID and its benefits: a multiple case analysis. *Assembly Automation*, 31(3), p. 251–262.
25. Zelbst, P.J., Green Jr, K.W., Sower, V.E. and Abshire, R.D., 2014. Impact of RFID and information sharing on JIT, TQM, and operational performance. *Management Research Review*, 37(11), pp. 970 - 989.